

# Alumil

Building excellence every day



 SMARTIA  
S61

FABRICATION MANUAL

V 10/2025

## INDEX - ΠΕΡΙΕΧΟΜΕΝΑ

◆ GENERAL MILLING - ΓΕΝΙΚΕΣ ΚΑΤΕΡΓΑΣΙΕΣ

---

◆ ASSEMBLY - ΣΥΝΑΡΜΟΛΟΓΗΣΗ ΕΞΑΡΤΗΜΑΤΩΝ

---

A large yellow graphic on the left side of the page, composed of several overlapping diagonal rectangular shapes in different shades of yellow, creating a dynamic, abstract design.

# GENERAL MILLING-TOOLING OPERATION

## ΓΕΝΙΚΕΣ ΚΑΤΕΡΓΑΣΙΕΣ

113 type crimping corner knives for frames  
 Μαχαιρία γωνιάστρας γωνιών τύπου 113 για κάσες

S61508,S61652,S61510	8510200300
	8510200700
	8510200300
	8510200700

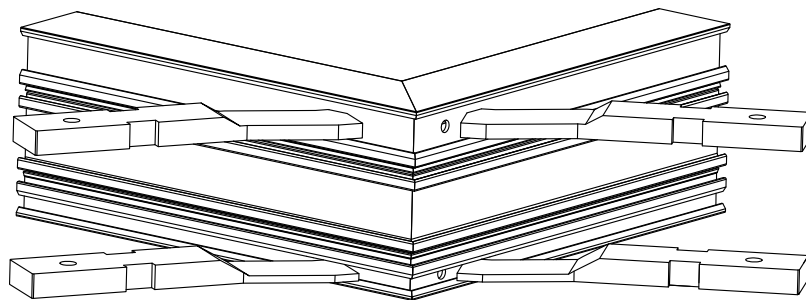
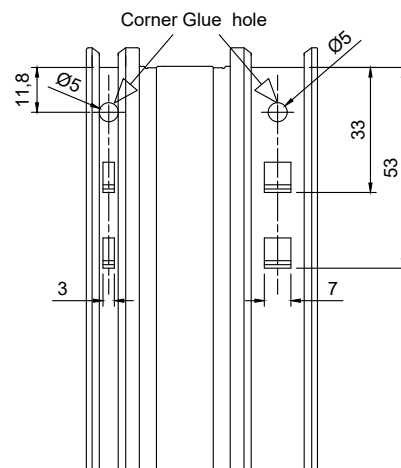
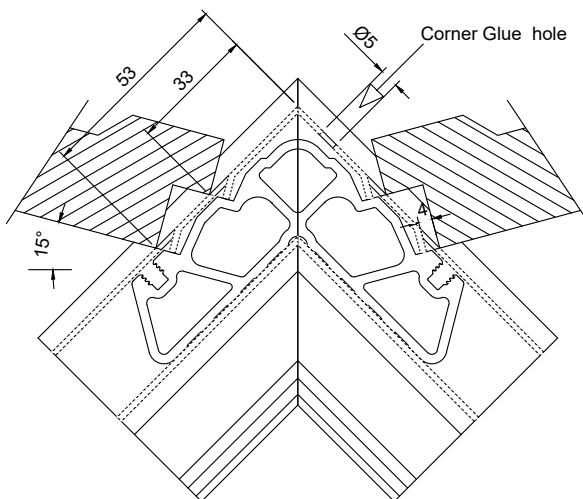

Crimp profiles with Knives

113 type crimping corner knives for frames  
 Μαχαιρία γωνιάστρας γωνιών τύπου 113 για κάσες

S61514	8510200300
	8510200700
	8510200300
	8510200700

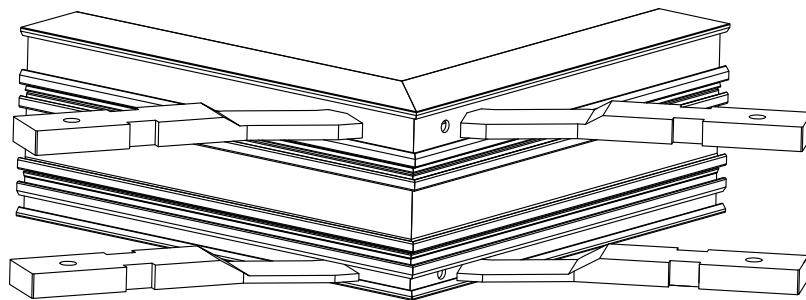
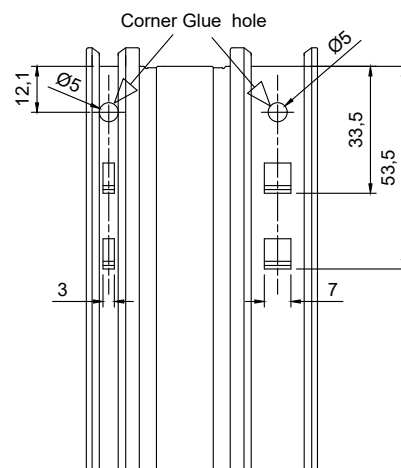
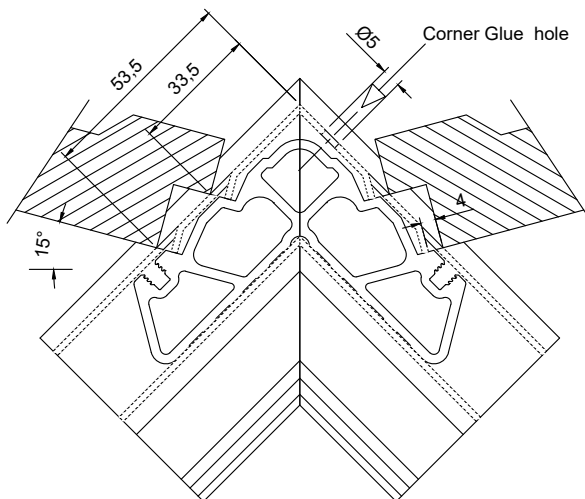

Crimp profiles with Knives

# 113 type corner cleat machining

## Κατεργασίες γωνιών τύπου 113

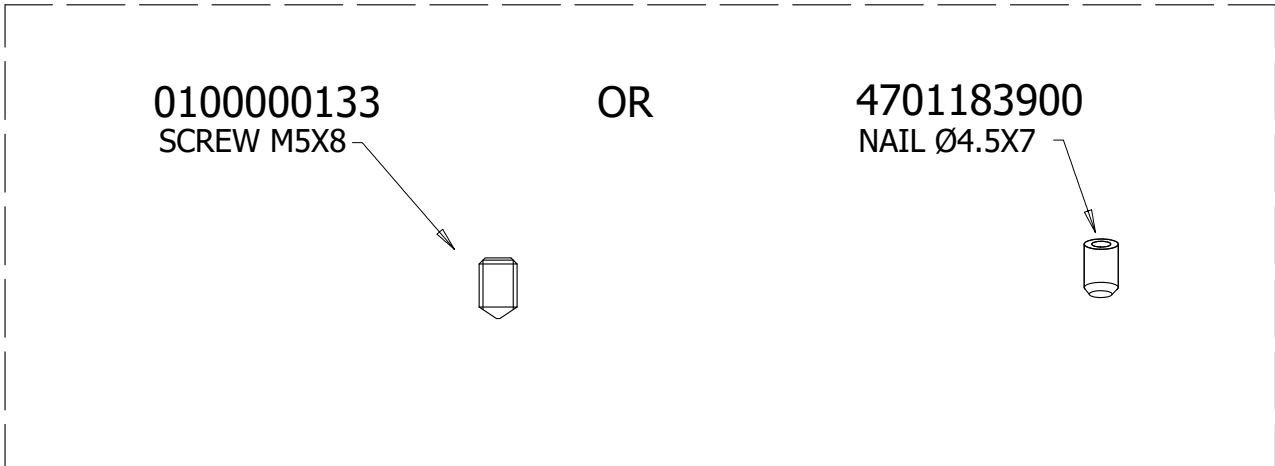

S61508,S61652,S61510

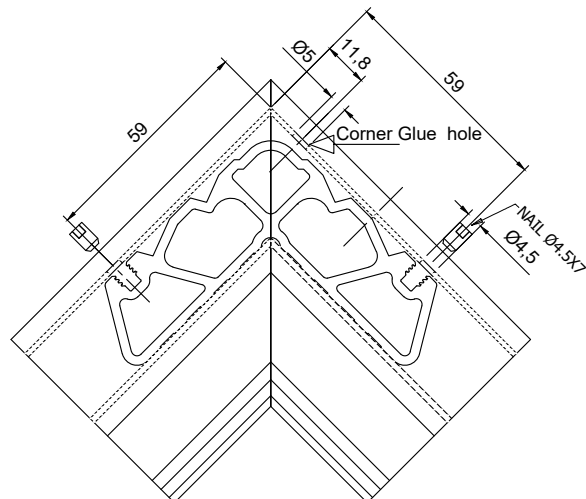

S61514

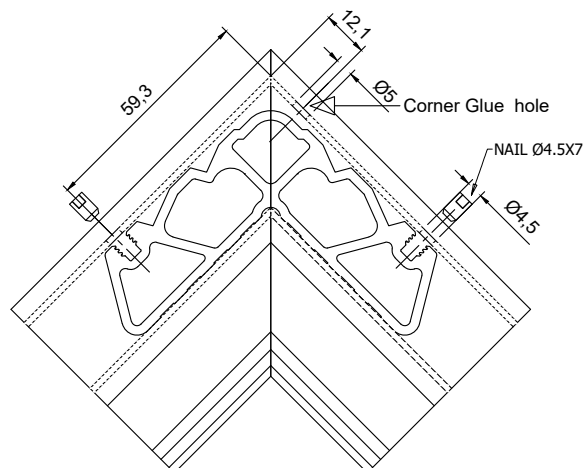

140 type crimping corner knives for frames  
 Μαχαιρία γωνιάστρας γωνιών τύπου 140 για κάσες

S61508,S61510	8517700300
	8517700100
	8517700300
	8517700100

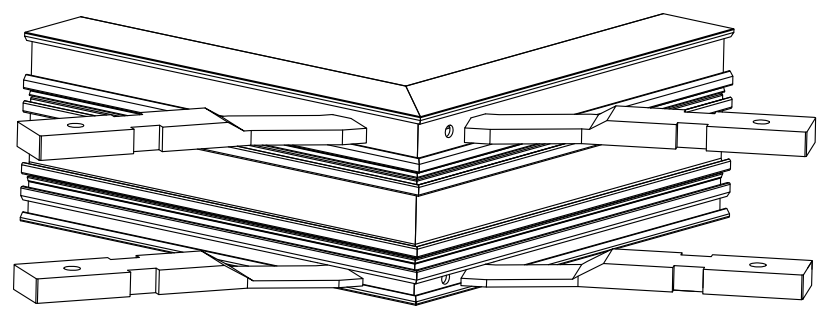
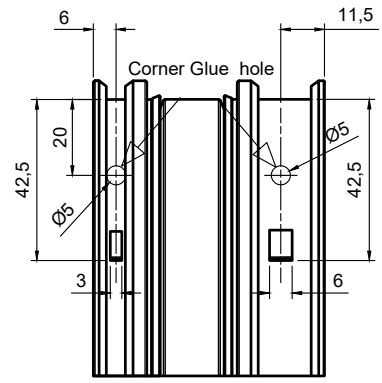
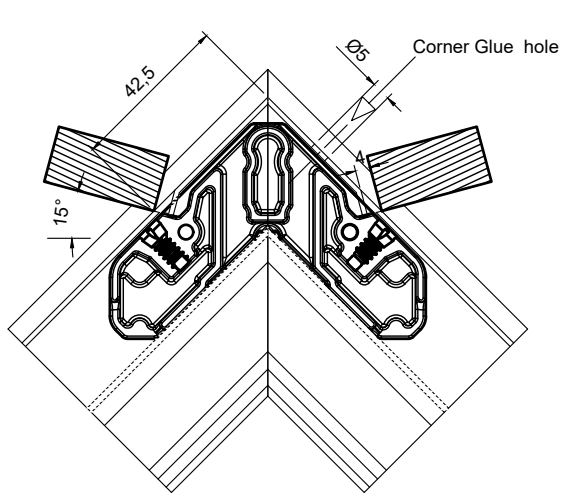

Crimp profiles with Knifes

140 type crimping corner knives for frames  
 Μαχαιρία γωνιάστρας γωνιών τύπου 140 για κάσες

S61514	8517700300
	8517700100
	8517700300
	8517700100

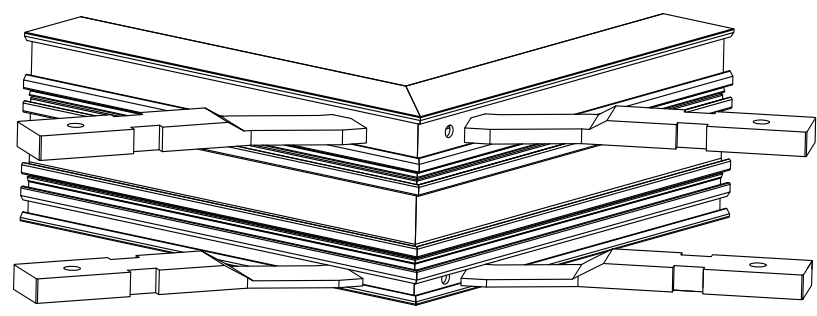
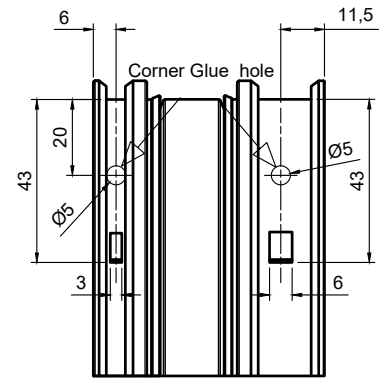
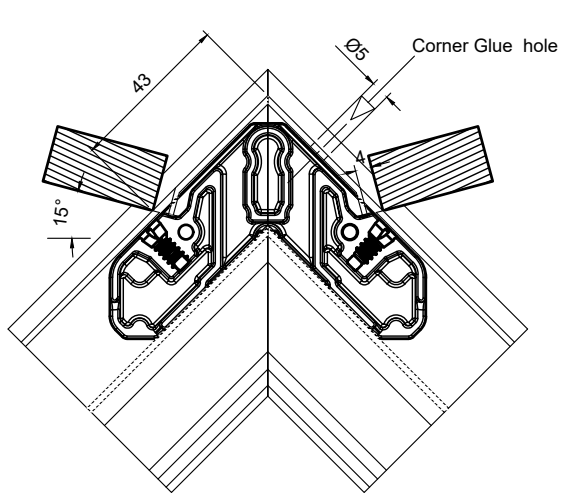

Crimp profiles with Knifes

140 type corner cleat machining  
Κατεργασίες γωνιών τύπου 140

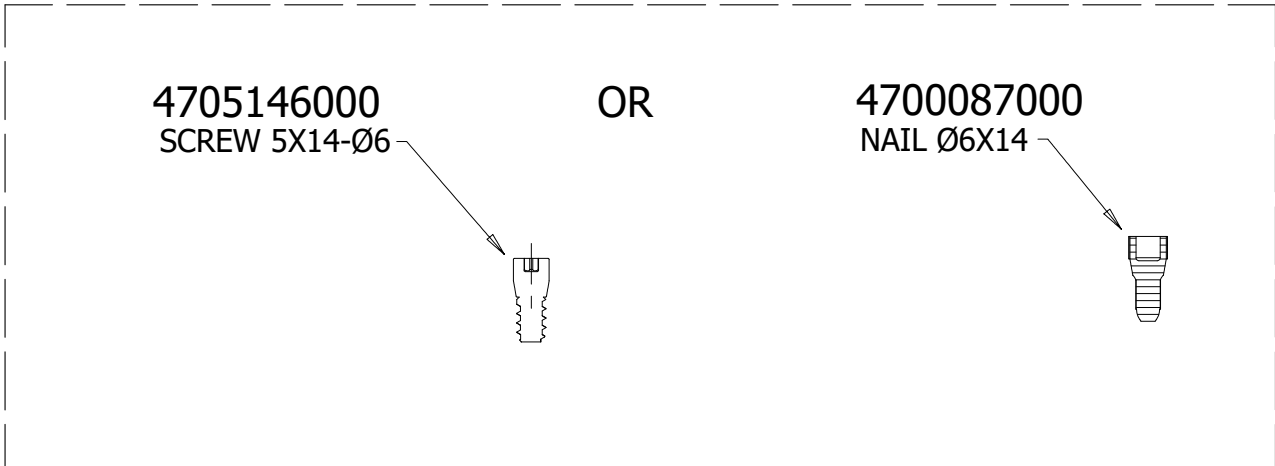

S61508,S61510

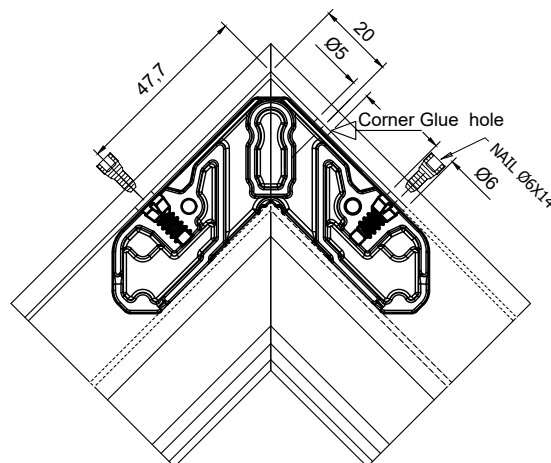

S61514

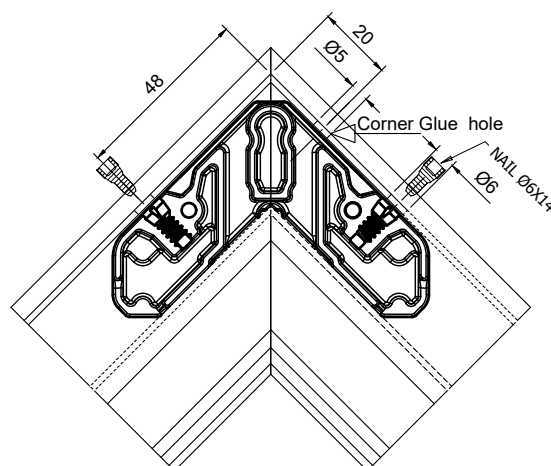

113 type crimping corner knives for sashes  
 Μαχαίρια γωνιάστρας γωνιών τύπου 113 για φύλλα

S61976,S61972,S61829,S61690	8510200300
	8510200700
	8510200300
	8510200700

8510200300

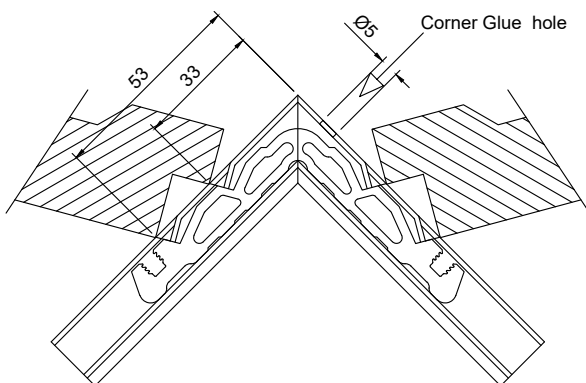

8510200700

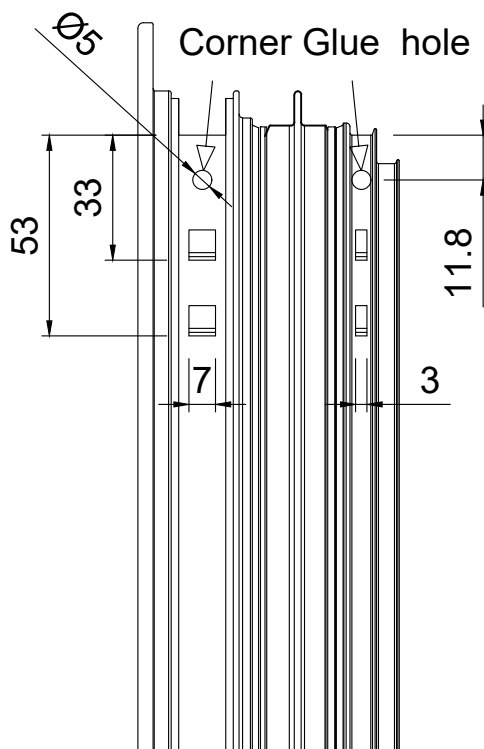
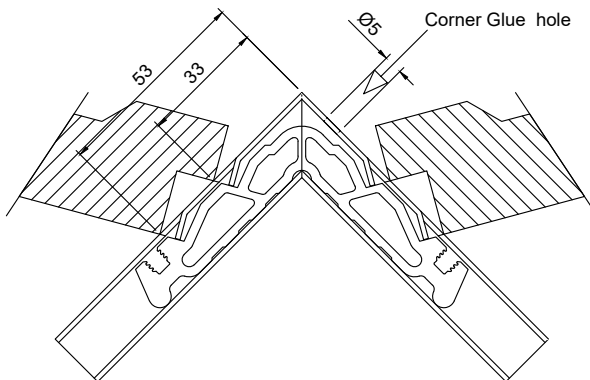

113 type crimping corner knives for sashes  
 Μαχαίρια γωνιάστρας γωνιών τύπου 113 για φύλλα

S61936,S61938,S61552,S61893	8510277000
	8510200700
	8510277000
	8510200700

8510277000

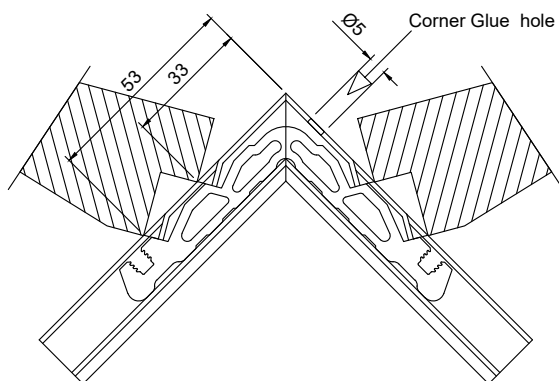

8510200700

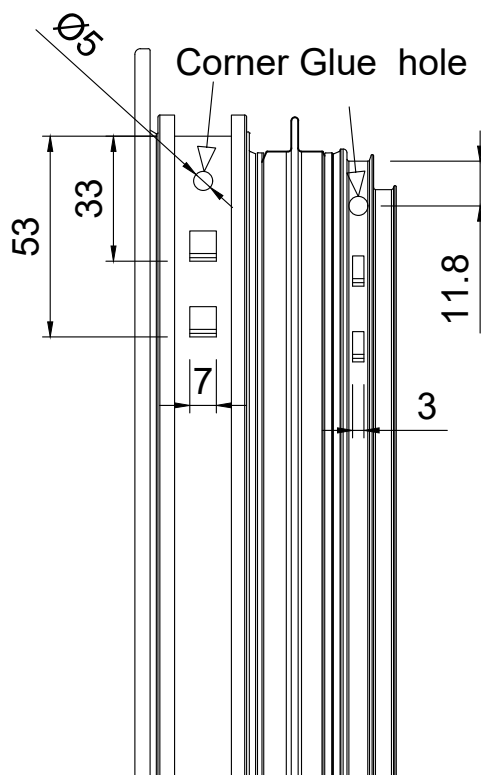
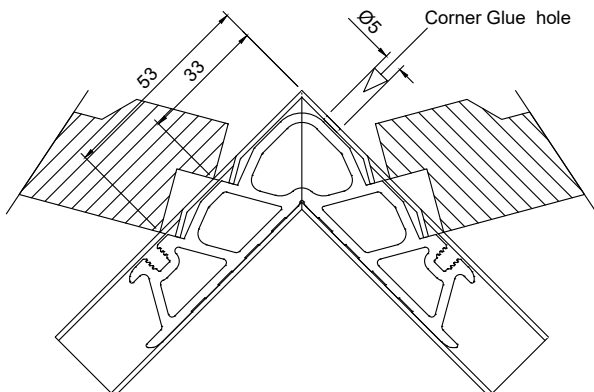

### 113 type corner cleat machining Κατεργασίες γωνιών τύπου 113

0100000133  
SCREW M5X8

OR

4701183900  
NAIL Ø4.5X7



Drilling jig for ext. chamber / Σαμπλόν κατεργασίας εξ. θαλάμου: 4706797000  
Drilling jig for int. chamber / Σαμπλόν κατεργασίας εσ. θαλάμου: 4706700000

S61976,S61972,S61829,S61690

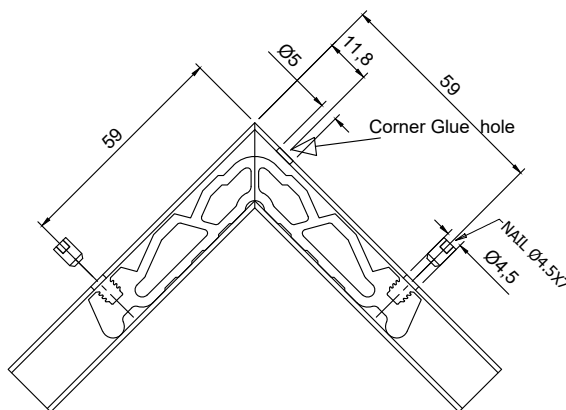

S61936,S61938,S61552,S61893

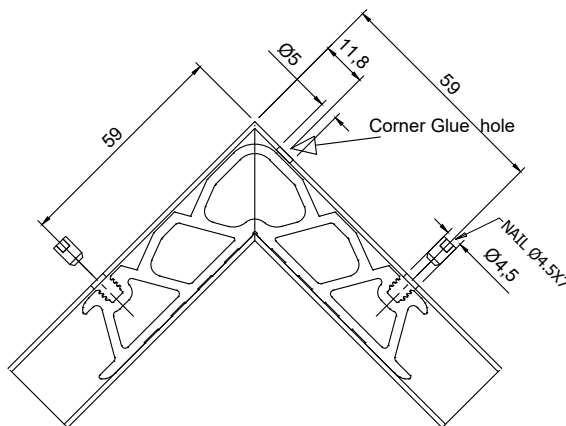

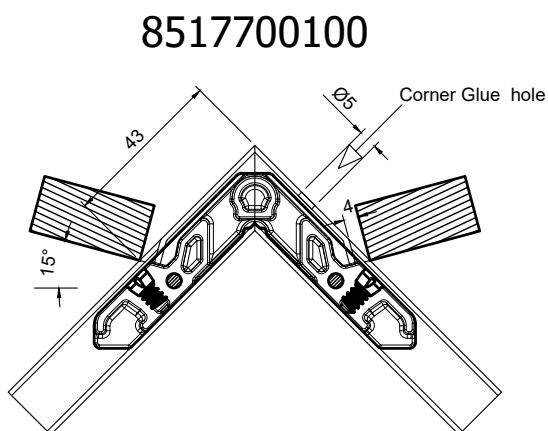
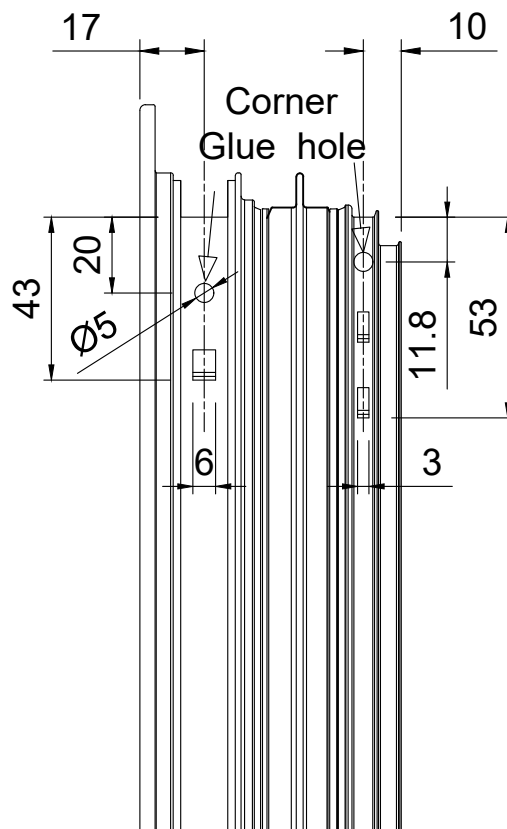
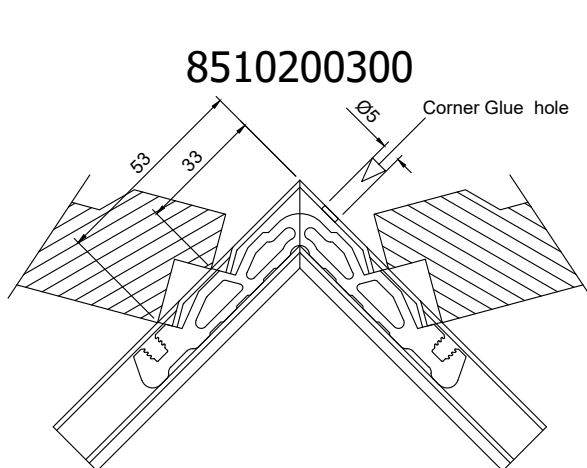

113 & 140 type crimping corner knives for sashes  
 Μαχαίρια γωνιάστρας γωνιών τύπου 113 & 140 για φύλλα

S61976	8510200300
	8517700100
	8510200300
	8517700100

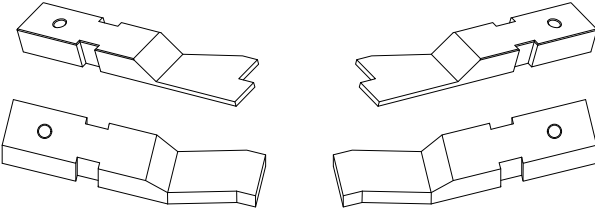

113 & 140 type crimping corner knives for sashes  
 Μαχαίρια γωνιάστρας γωνιών τύπου 113 & 140 για φύλλα

S61936	8510277000
	8517700100
	8510277000
	8517700100

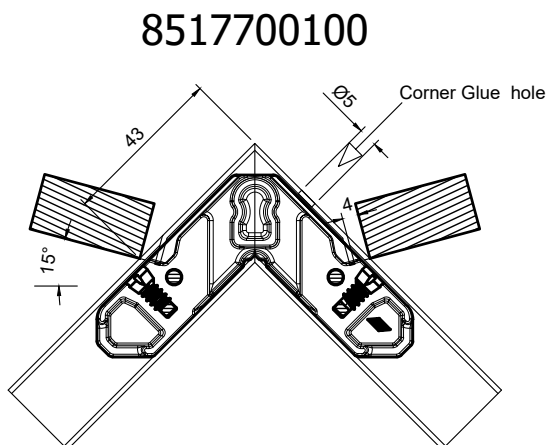
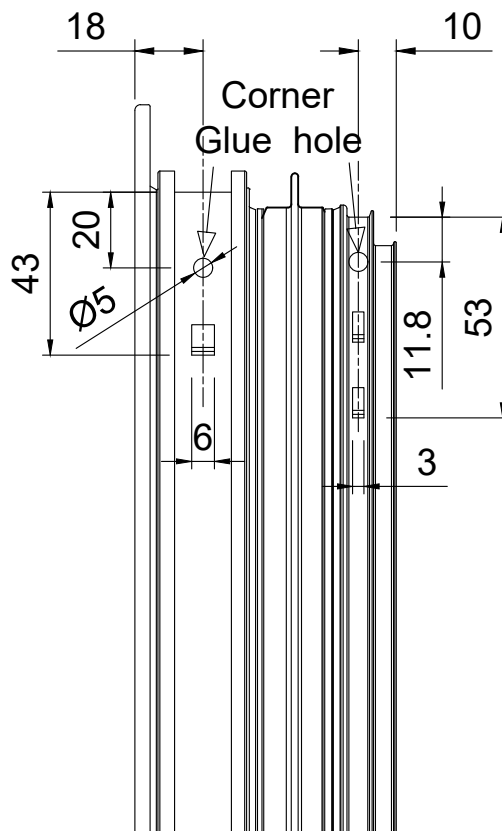
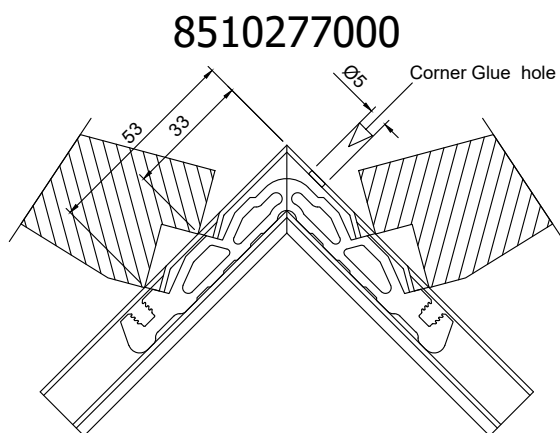

## 113 & 140 type corner cleat machining Κατεργασίες γωνιών τύπου 113 & 140

0100000133  
SCREW M5X8



4705146000  
SCREW 5X14-Ø6



OR

4701183900  
NAIL Ø4.5X7



4700087000  
NAIL Ø6X14



Drilling jig for ext. chamber / Σαμπλόν κατεργασίας εξ. θαλάμου: 4706797000

S61976,S61936

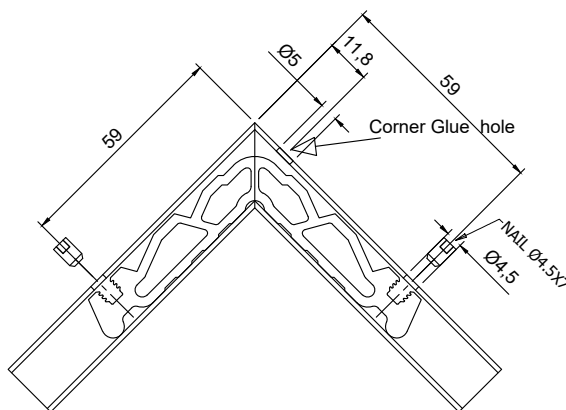

S61936

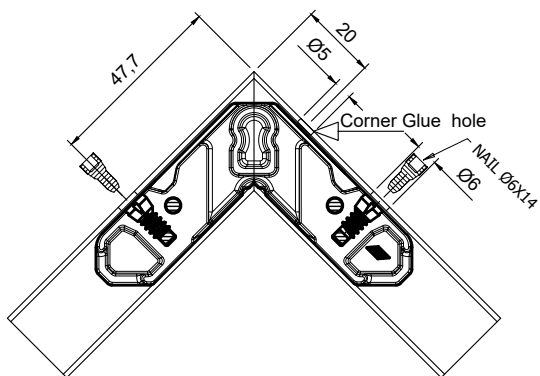

S61976

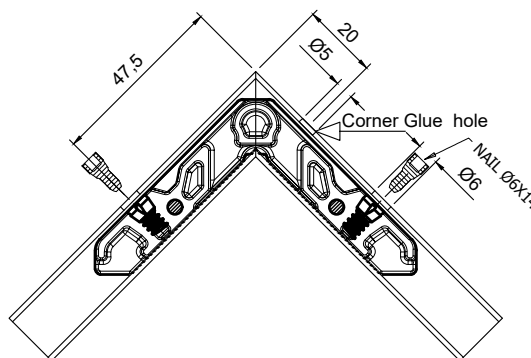

# Drainage Απορροές

FIXED FRAME WATER EVACUATION MILLINGS  
ΚΑΤΕΡΓΑΣΙΕΣ ΑΠΟΡΡΟΗΣ ΣΤΑΘΕΡΟΥ ΠΛΑΙΣΙΟΥ

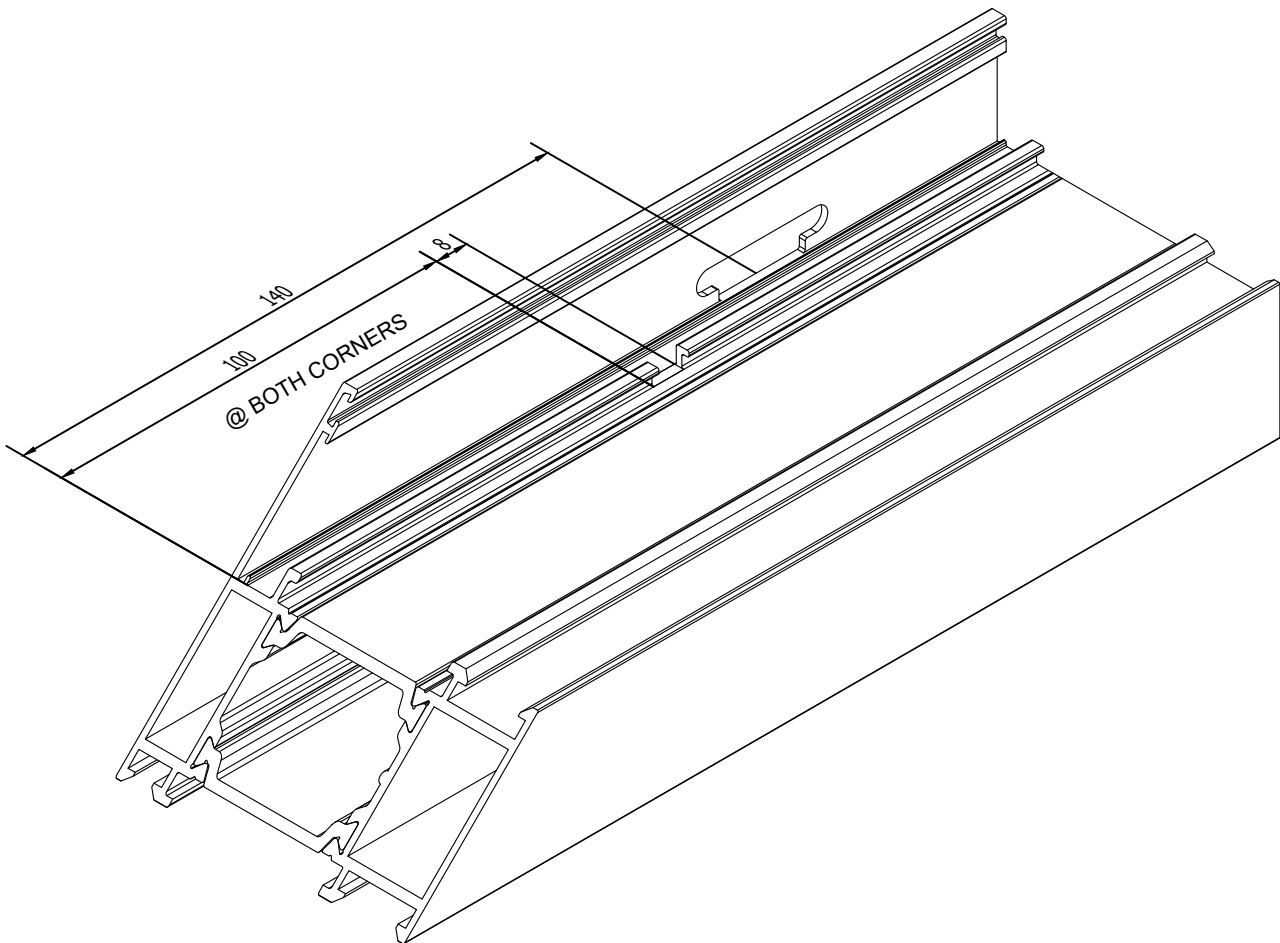
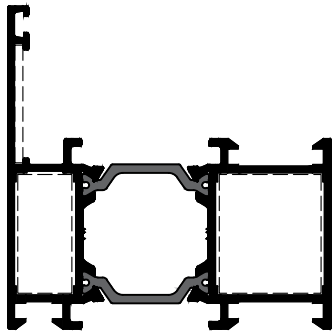

## Frame drainage Απορροές κάσας

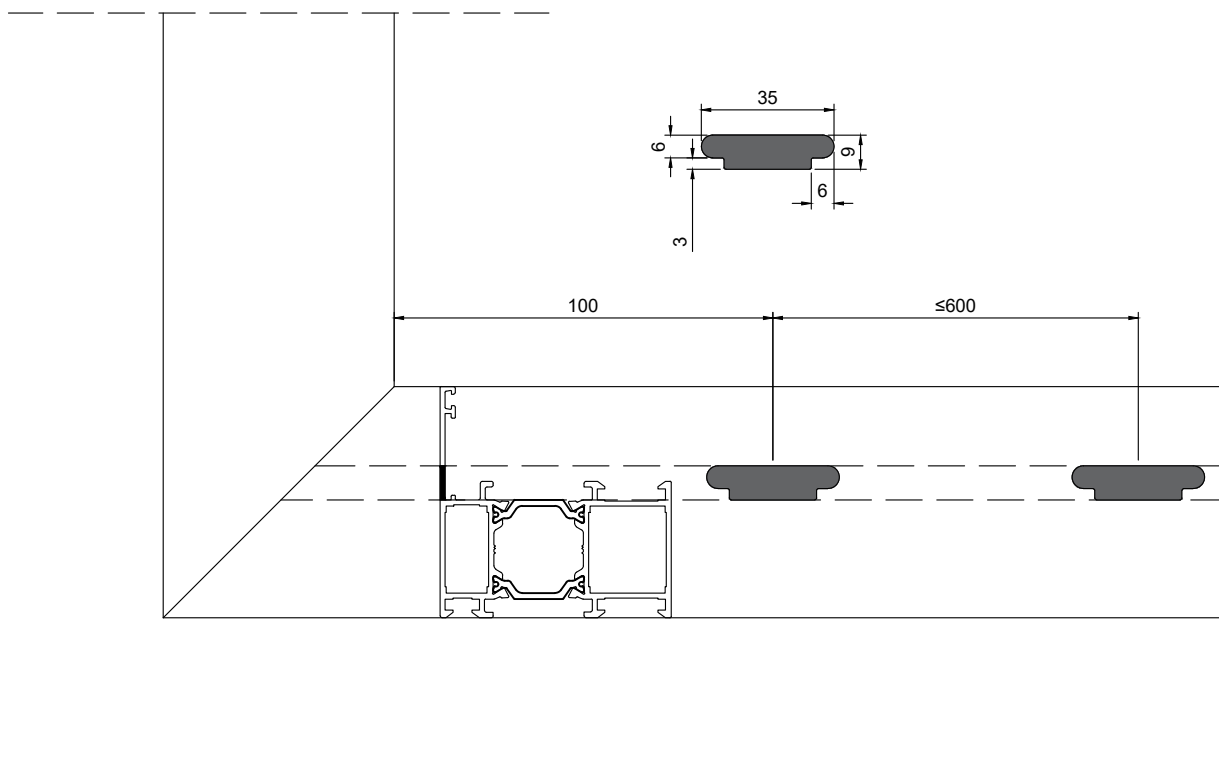

Punch press / Πρεσάκι:

8002020100 + 8002020145

Profile / Προφίλ:

S61508 / S61510 / S61514 / S61652 / S61906

## T-profile drainage Αποροές Ταυ

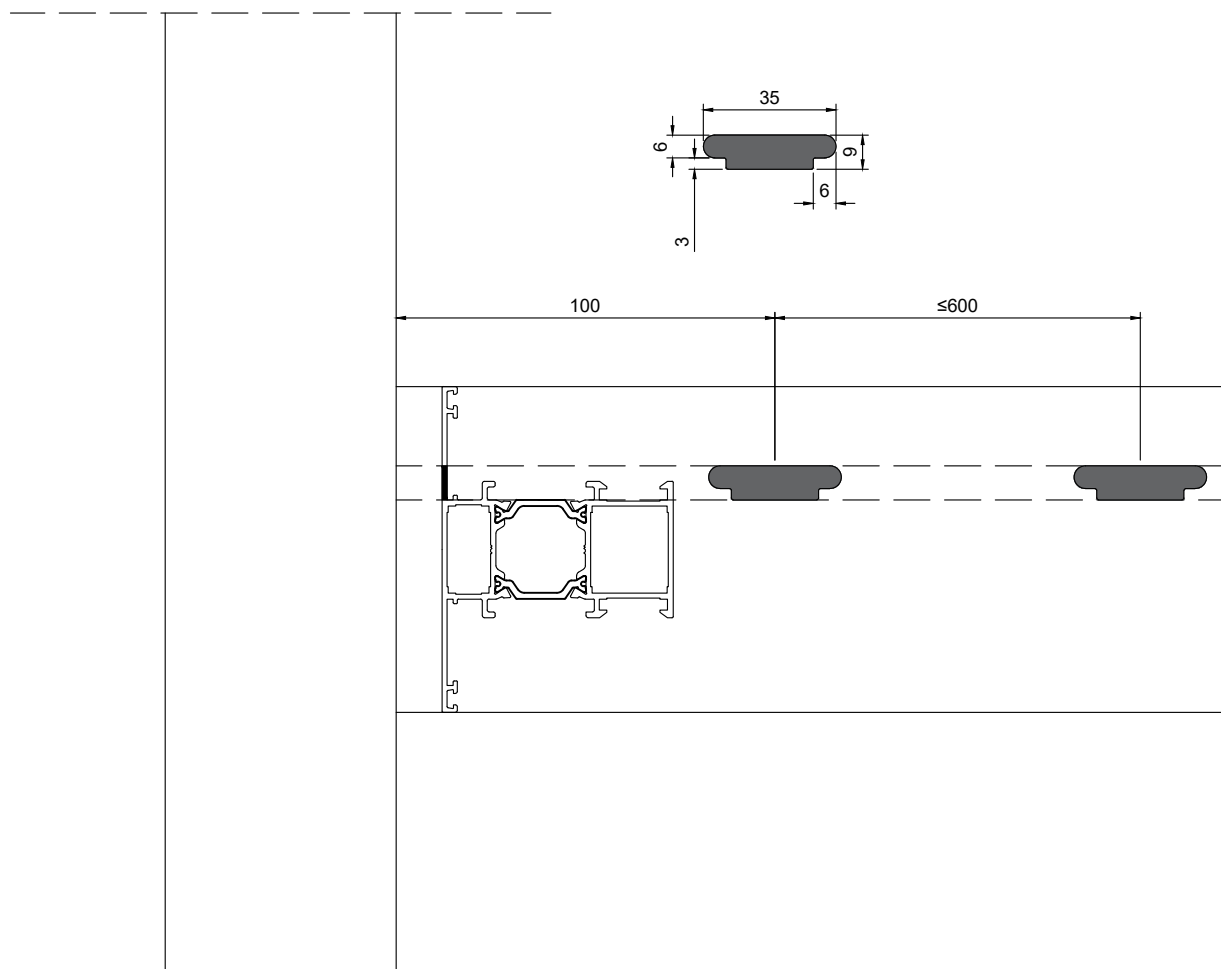

Punch press / Πρεσάκι:

8002020100 + 8002020145

Profile / Προφίλ:

S61656 / S61564 / S61776 / S61770 / S61260

## Sash drainage Απορροές φύλλου

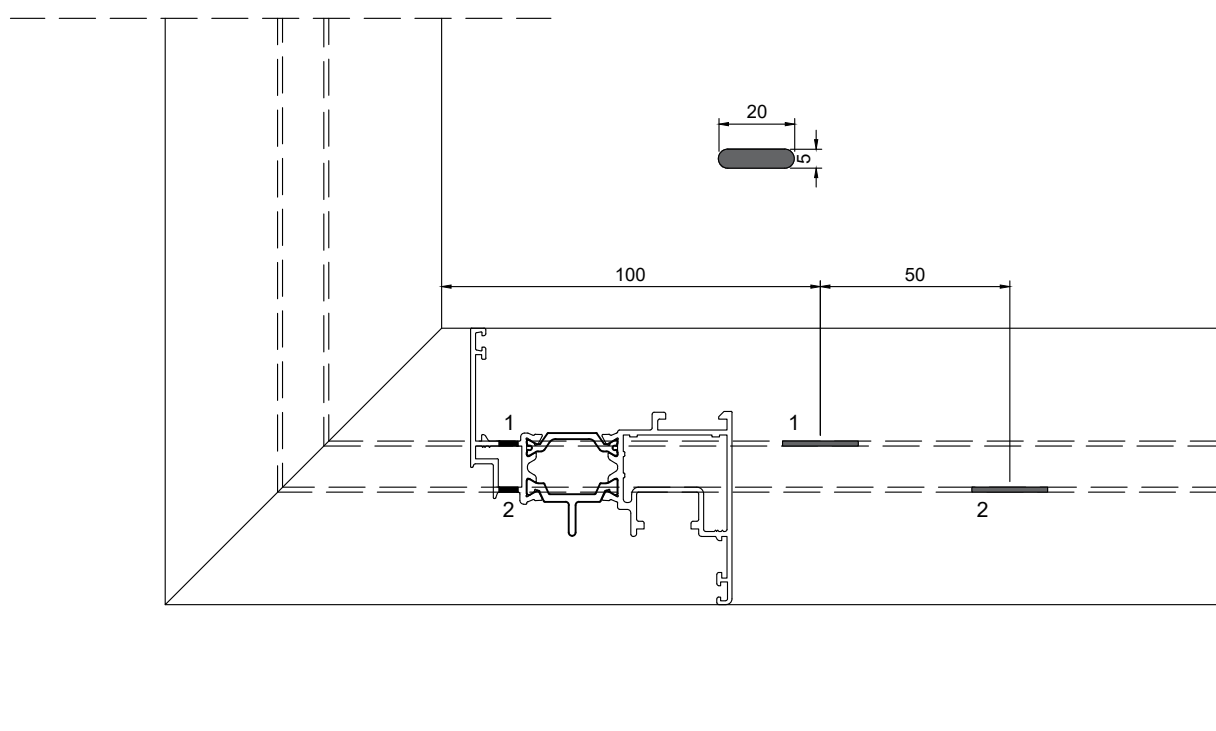

Profile / Προφίλ:

S61976 / S61972 / S61829 / S61690  
S61936 / S61938 / S61552 / S61893

Machining for T-profile  
Κατεργασία Ταυ

Machining tool / Φρέζα - 8526100000

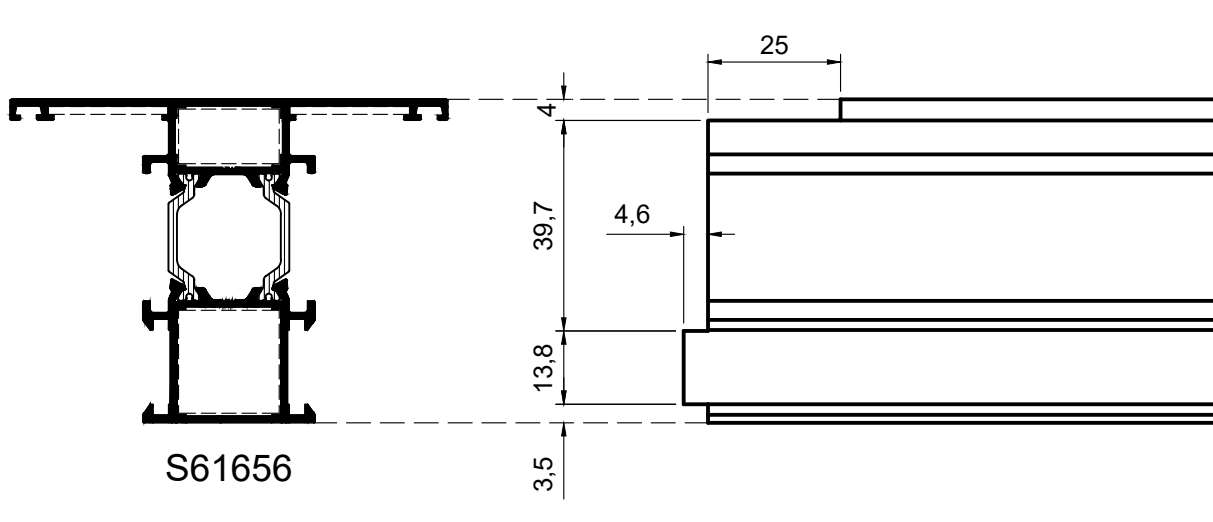

S61656

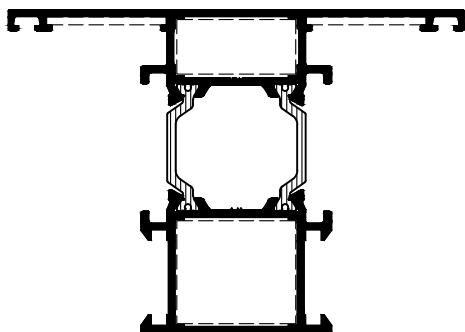

S61564

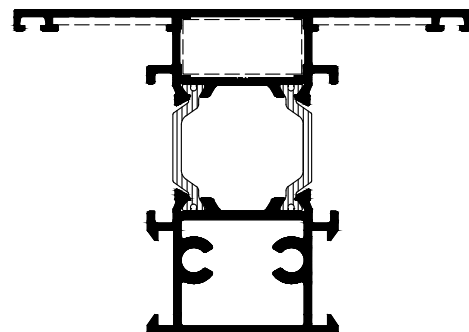

S61260

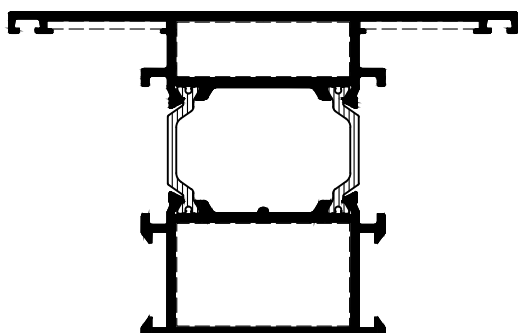

S61776

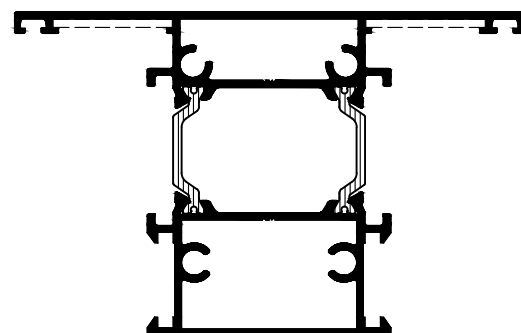

S61770

Machining for nails for T-profile  
 Κατεργασία πείρου για Ταυ

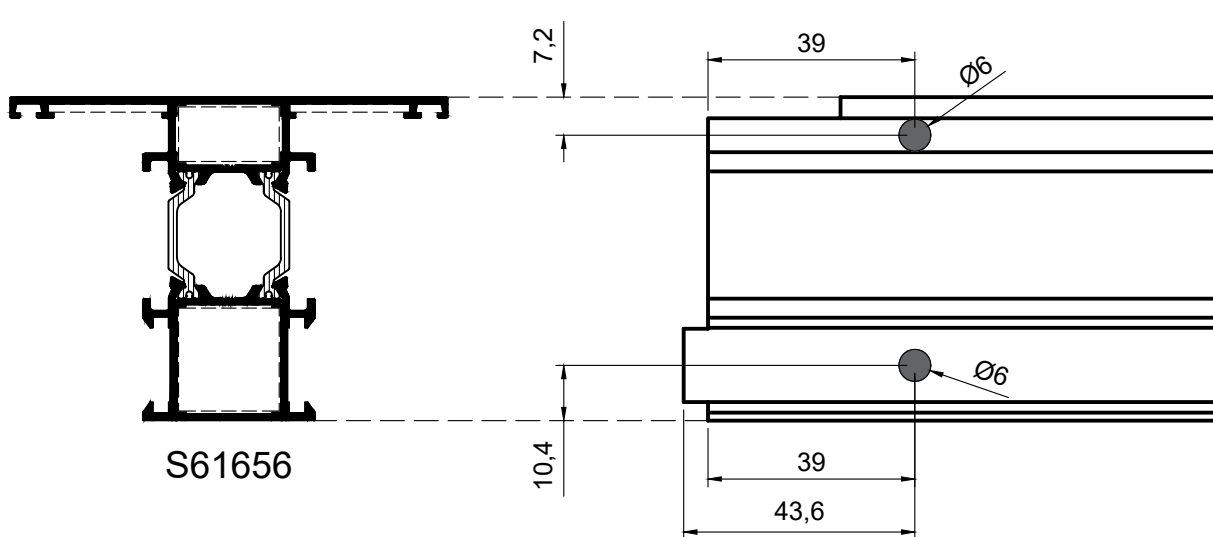

S61656

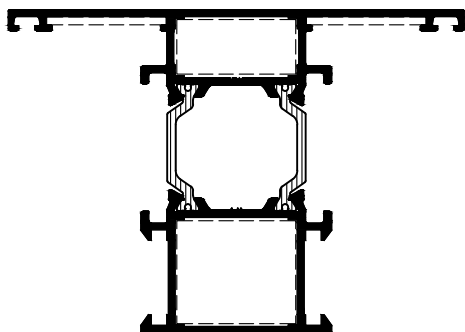

S61564

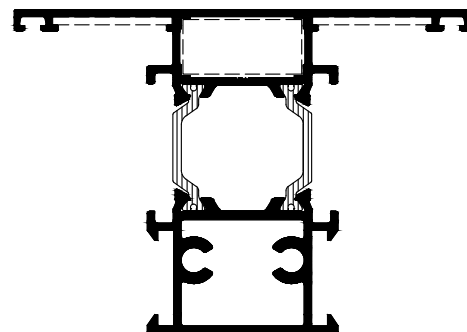

S61260

\*nail only on the outer chamber

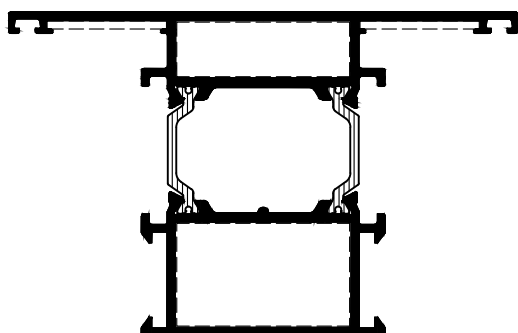

S61776

# Frame machining for T-profile

## Κατεργασία κάσας για σύνδεση Ταυ

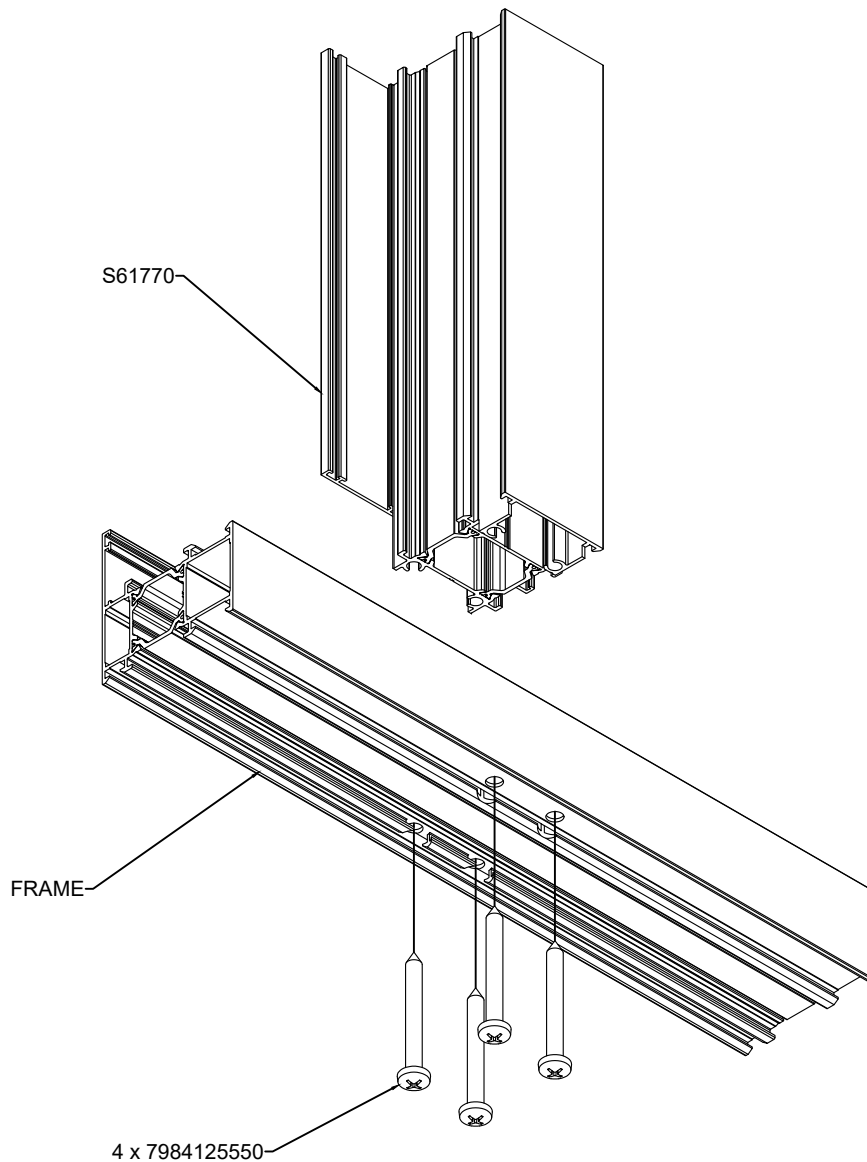
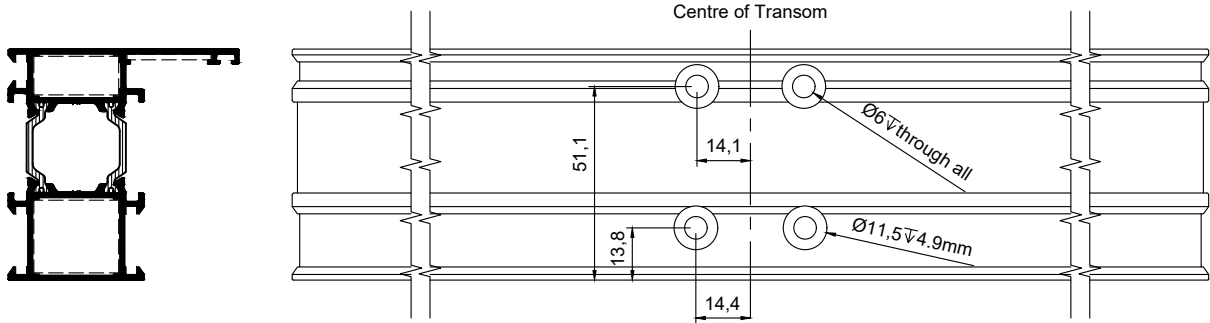

Frame machining for T connecting  
Κατεργασία τύπου Ταυ για κάσα

Machining tool / Φρέζα - 8526100000

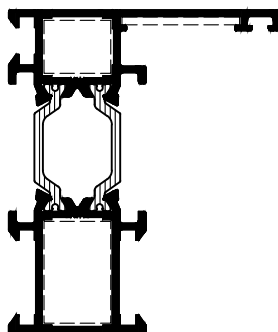
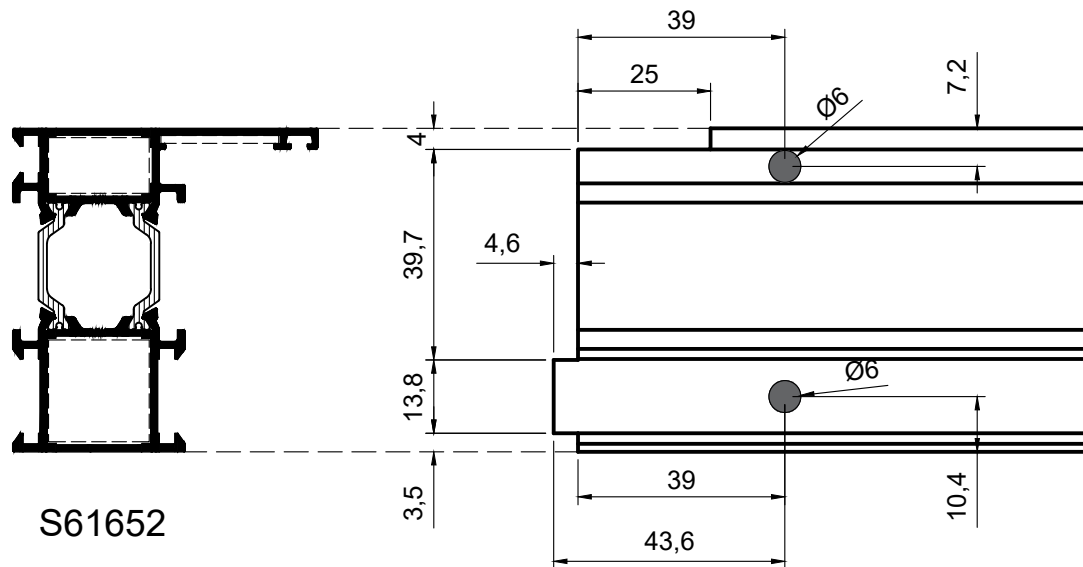

S61508

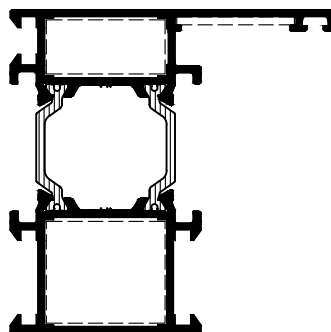

S61510

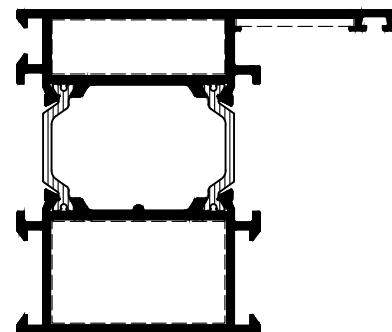

S61514

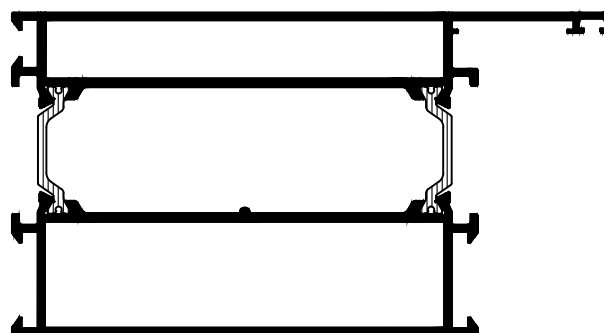

S61906

## Handle milling operation Κατεργασία λαβής

### Alumil PVC Groove Mechanism

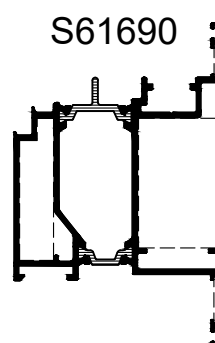
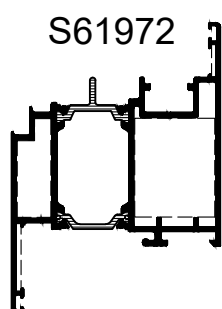
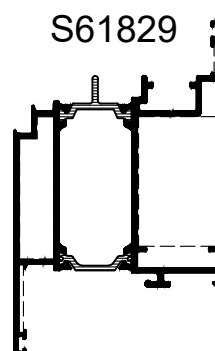
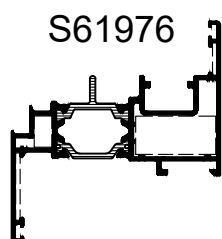

Alumil PVC Groove Mechanism - Basic Security  
Περιμετρικός Μηχανισμός Alumil - Βασικό Επίπεδο Ασφαλείας

Handle / Cremone milling operation  
 Κατεργασία λαβής / σπανιολέτας

Alumil Euro Groove Mechanism (Standard, Advanced)

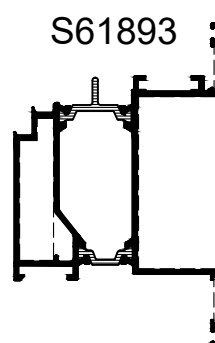
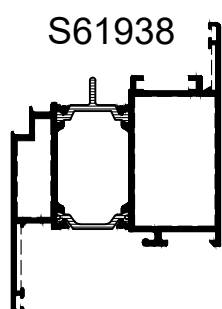
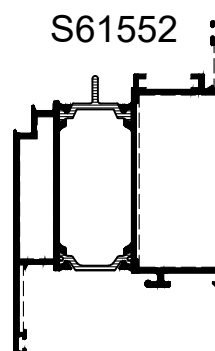
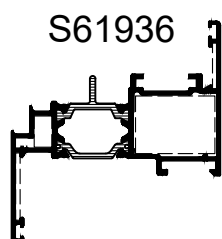

Alumil Standard T/T Mechanism 100kg  
 Μηχανισμός Standard A/A Alumil 100kg



Alumil Advanced T/T Mechanism 150kg  
 Μηχανισμός Advanced A/A Alumil 150kg



New Alumil Standard T/T Mechanism 130kg  
 Νέος Μηχανισμός Standard A/A Alumil 130kg



Alumil Euro Groove T/T Concealed Mechanism 180kg  
 Κρυφός Μηχανισμός Euro Groove A/A Alumil 180kg



Alumil Euro Groove T/T Concealed Mechanism 150kg  
 Κρυφός Μηχανισμός Euro Groove A/A Alumil 150kg

Slave sash handle milling operation for adjoining profile S61658  
 Alumil Euro Groove mechanism (Standard)  
 Κατεργασία λαβής βοηθητικού φύλλου για μπινι S61658

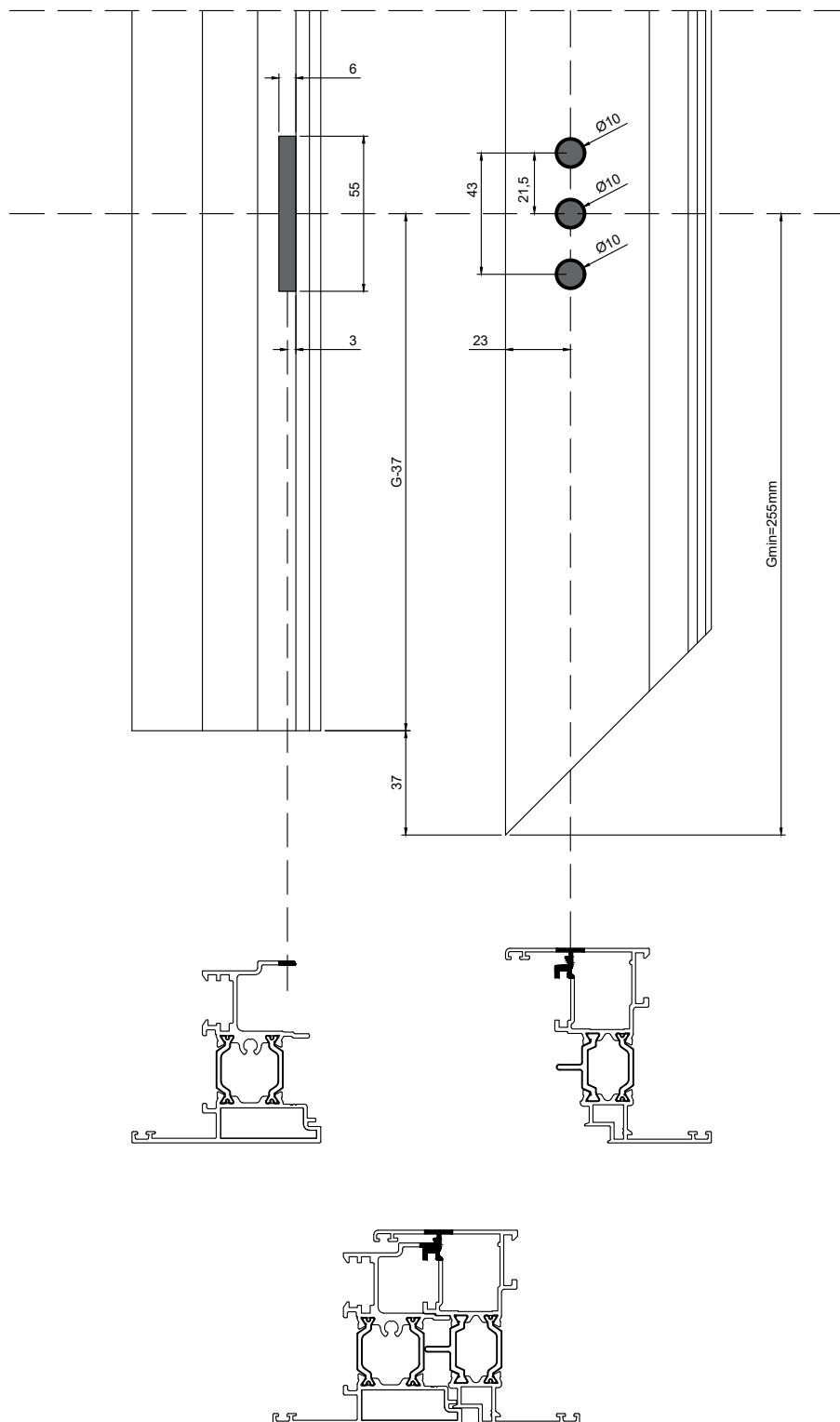

## Machinings for screwing adjoining profile with sash Κατεργασίες για βίδωμα μπινιού με φύλλο

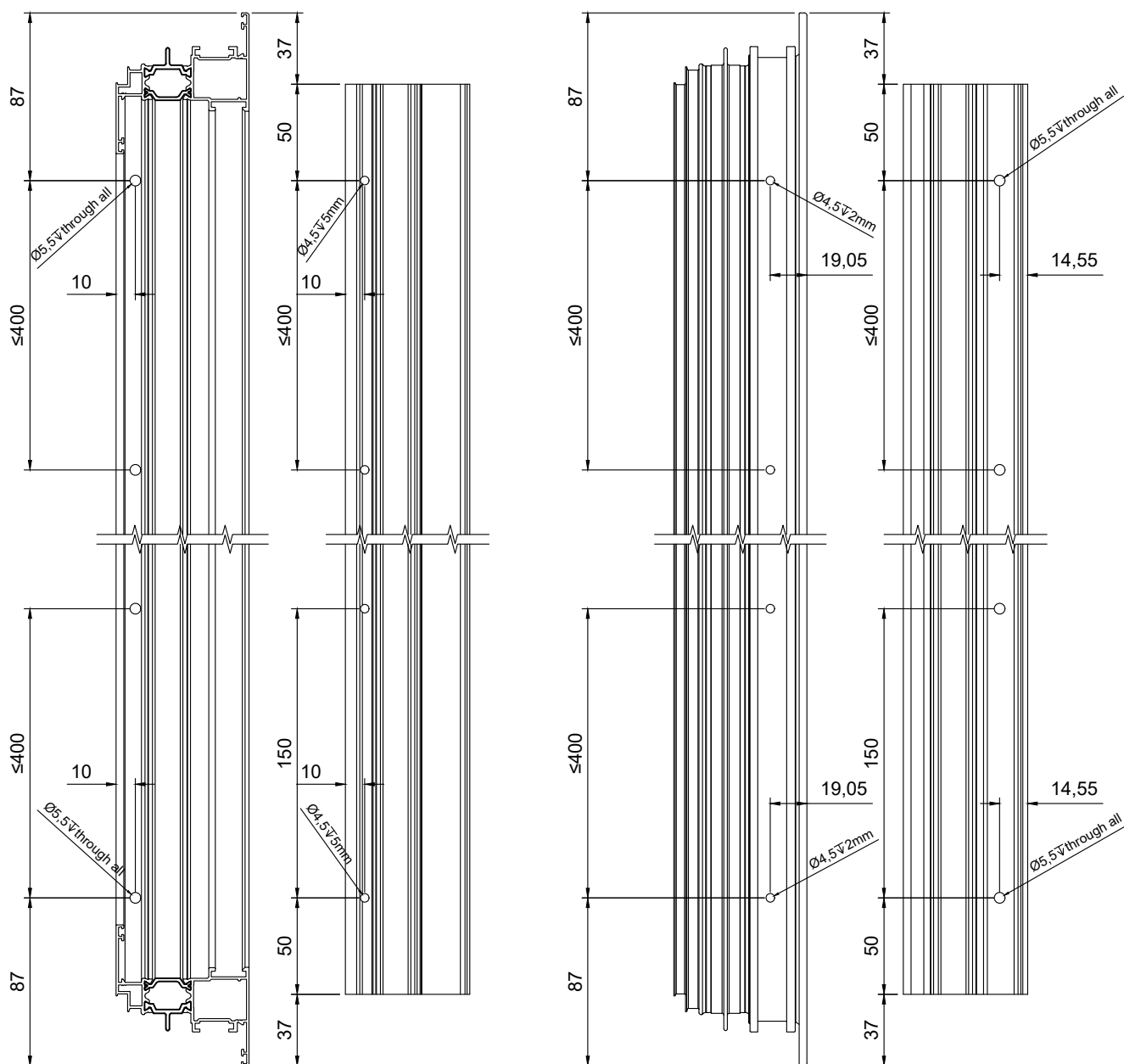
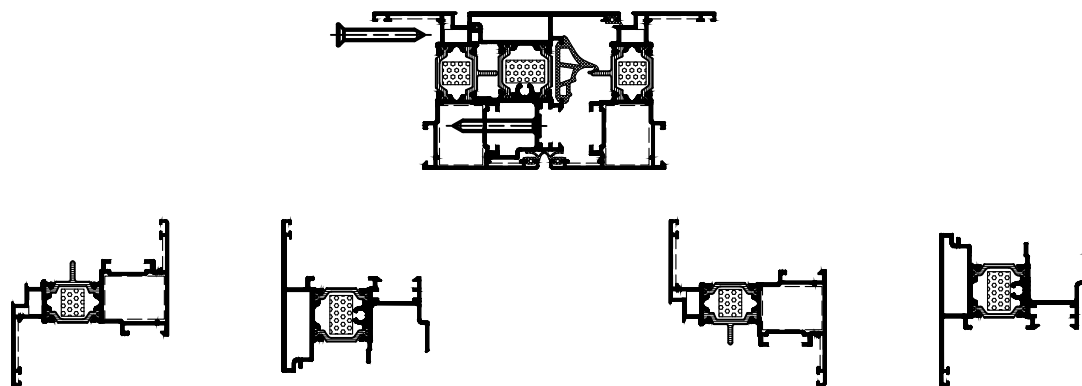

Slave sash handle milling operation for adjoining profile S61658  
 Alumil Euro Groove mechanism (Standard)  
 Κατεργασία λαβής βοηθητικού φύλλου για μπινι S61658

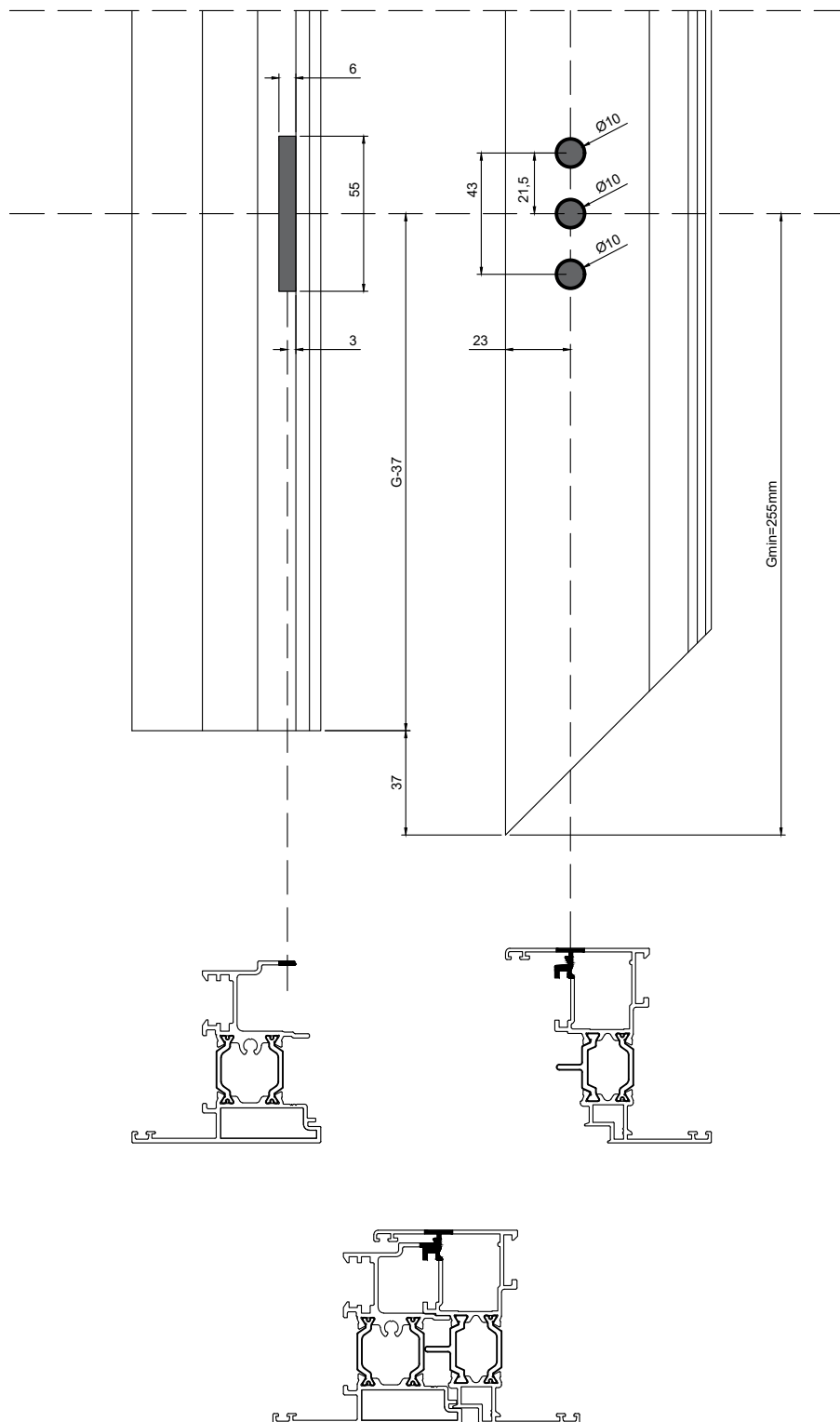

Slave sash handle milling operation for adjoining profile S61658  
 Alumil Euro Groove mechanism (Standard)  
 Κατεργασία λαβής βοηθητικού φύλλου για μπινι S61658

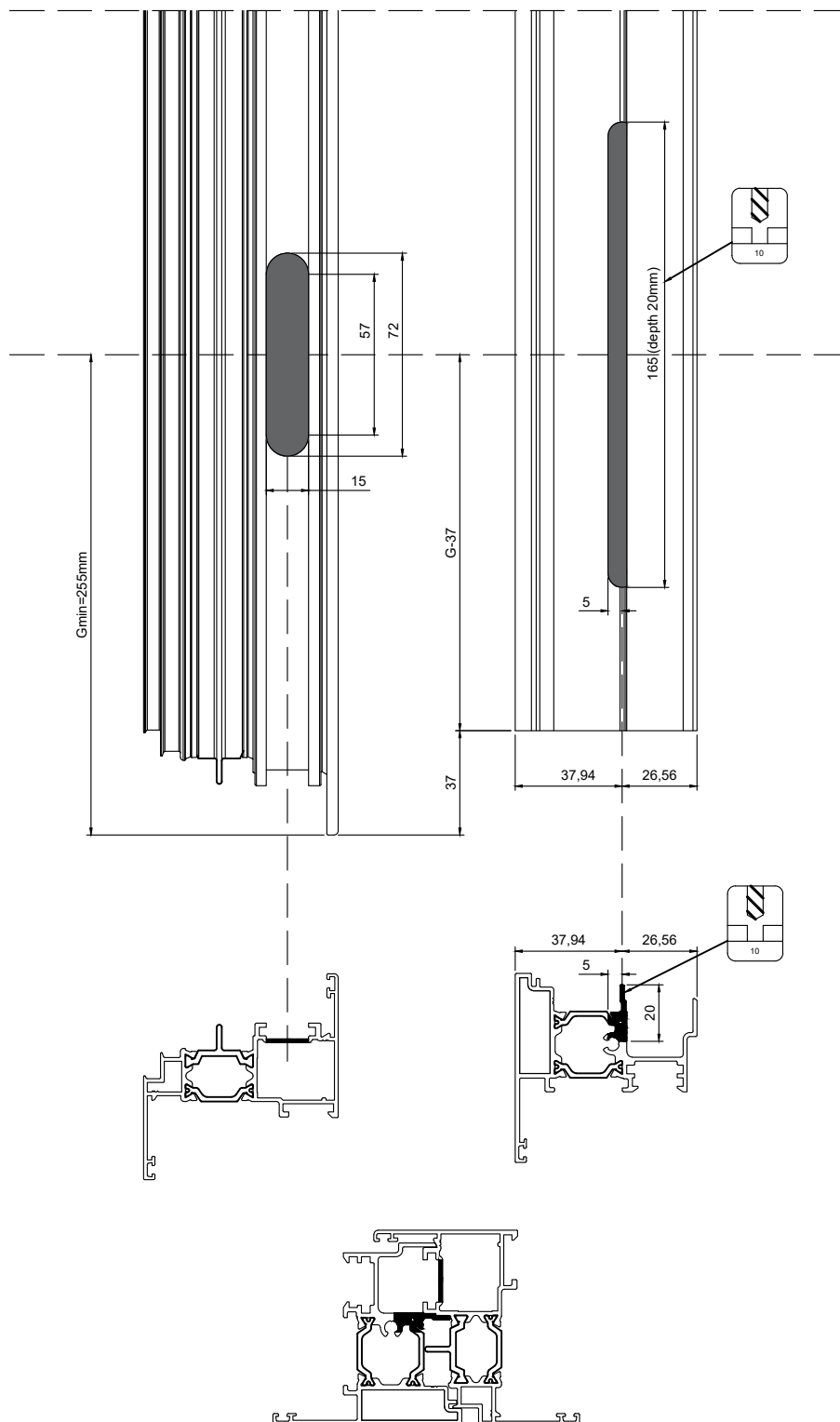

Slave sash handle milling operation for adjoining profile S61658  
 Alumil Euro Groove mechanism (Standard)  
 Κατεργασία λαβής βοηθητικού φύλλου για μπινι S61658

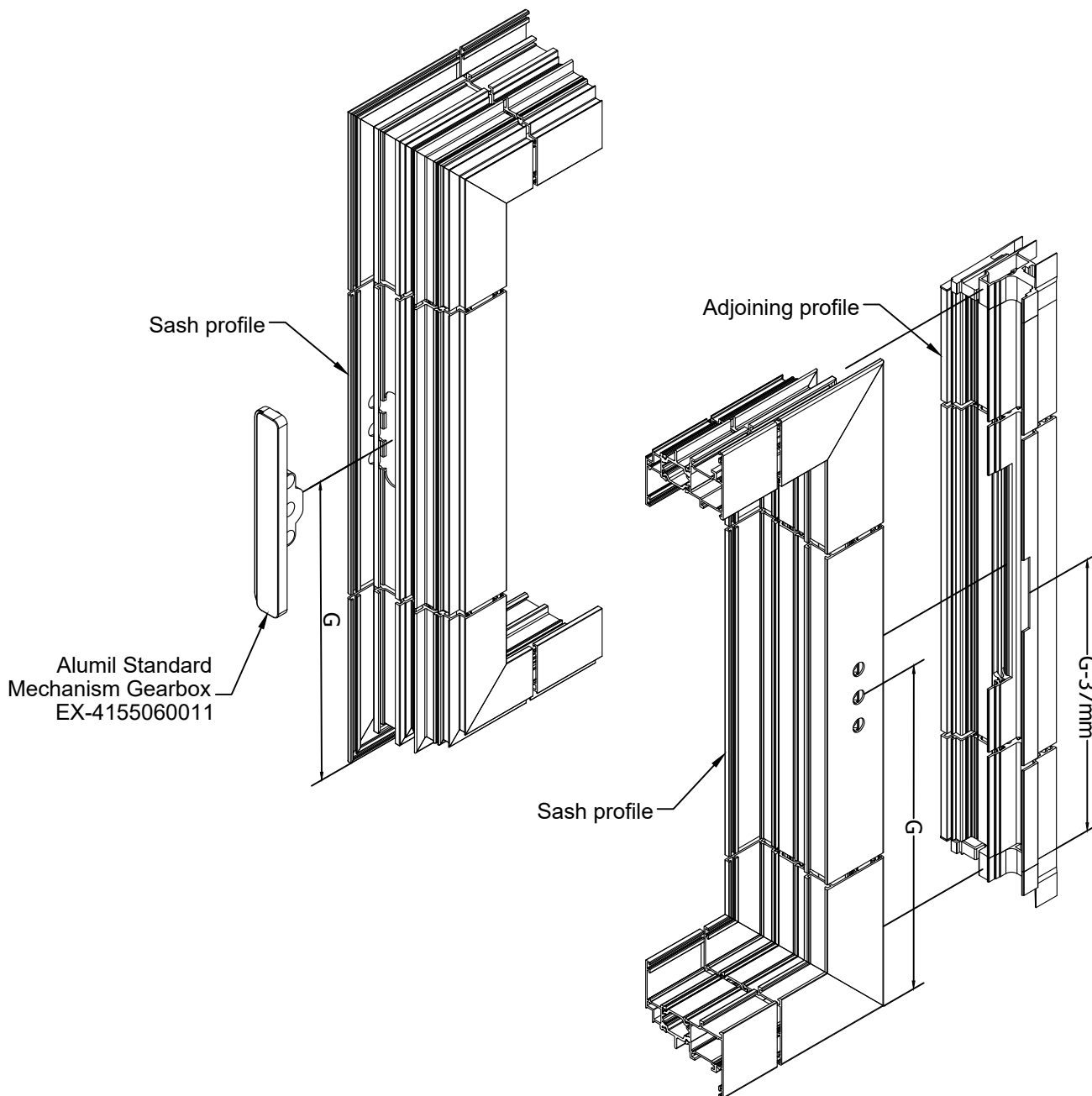

## Locks - Κλειδαριές

**\* Note / Σημείωση**

Please consult the Door Hardware Catalogue to find all option regarding door locking solutions, cylinders, door pin handles, fixed external handles and escutcheons

Για επιλογές κλειδαριών, κυλίνδρων, λαβών με καρέ, σταθερών εξωτερικών λαβών και ροζετών, συμβουλευτείτε τον κατάλογο εξαρτημάτων πορτών



## Locks machinings Κατεργασίες κλειδαριών

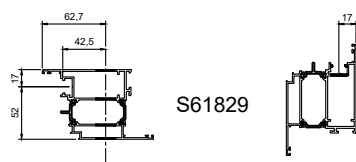
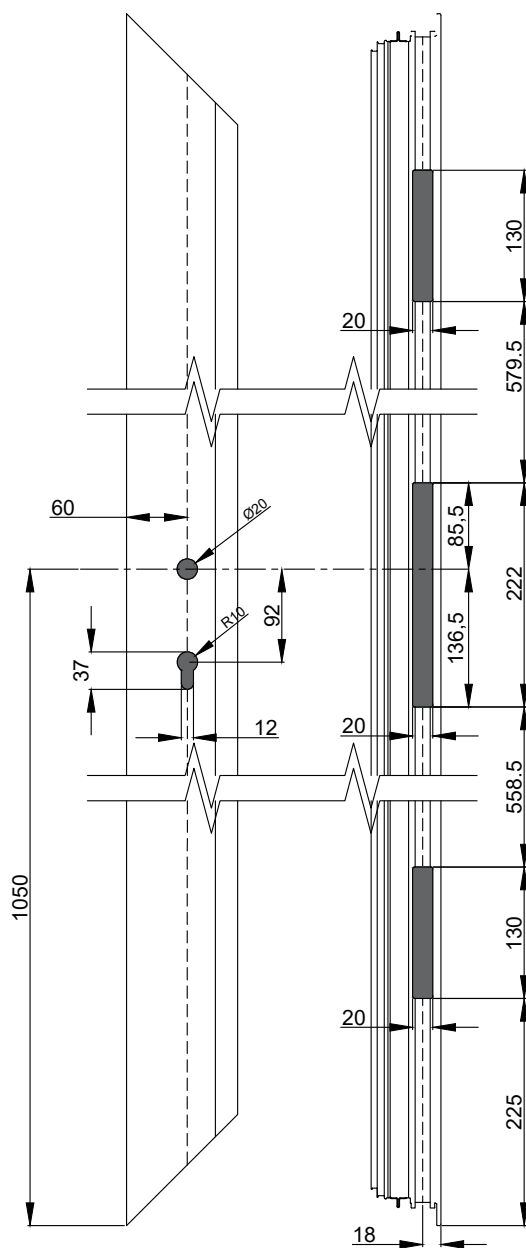
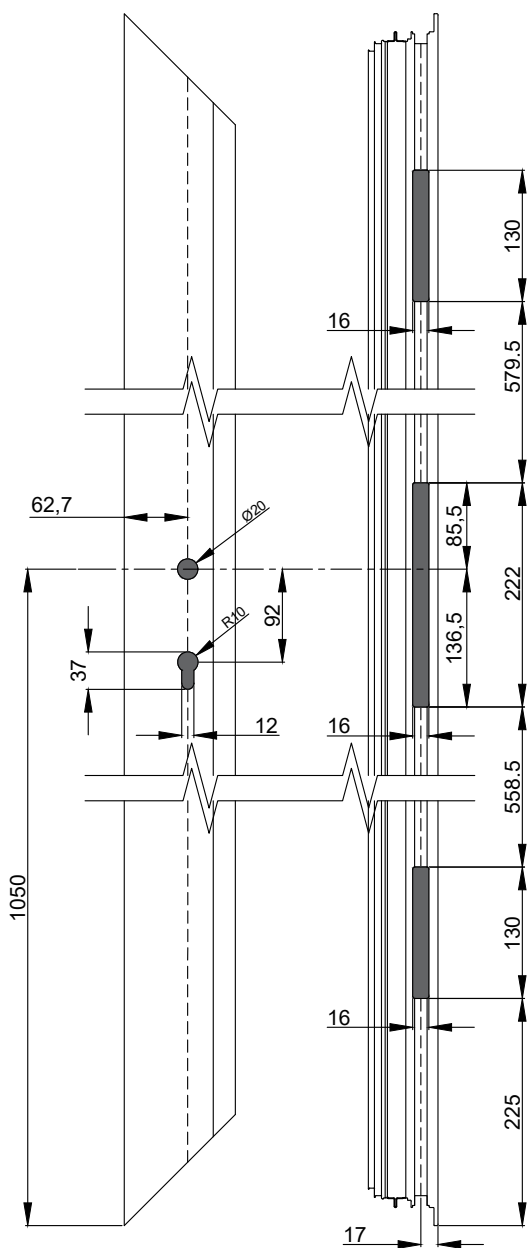

S61829

S61690

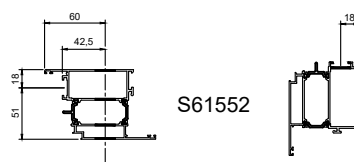

S61552

S61893



# ASSEMBLY FOR ACCESSORIES

## ΣΥΝΑΡΜΟΛΟΓΗΣΗ ΕΞΑΡΤΗΜΑΤΩΝ

## Assembly of S61 Adjoining Profile Συναρμολόγηση S61 Μπινιού

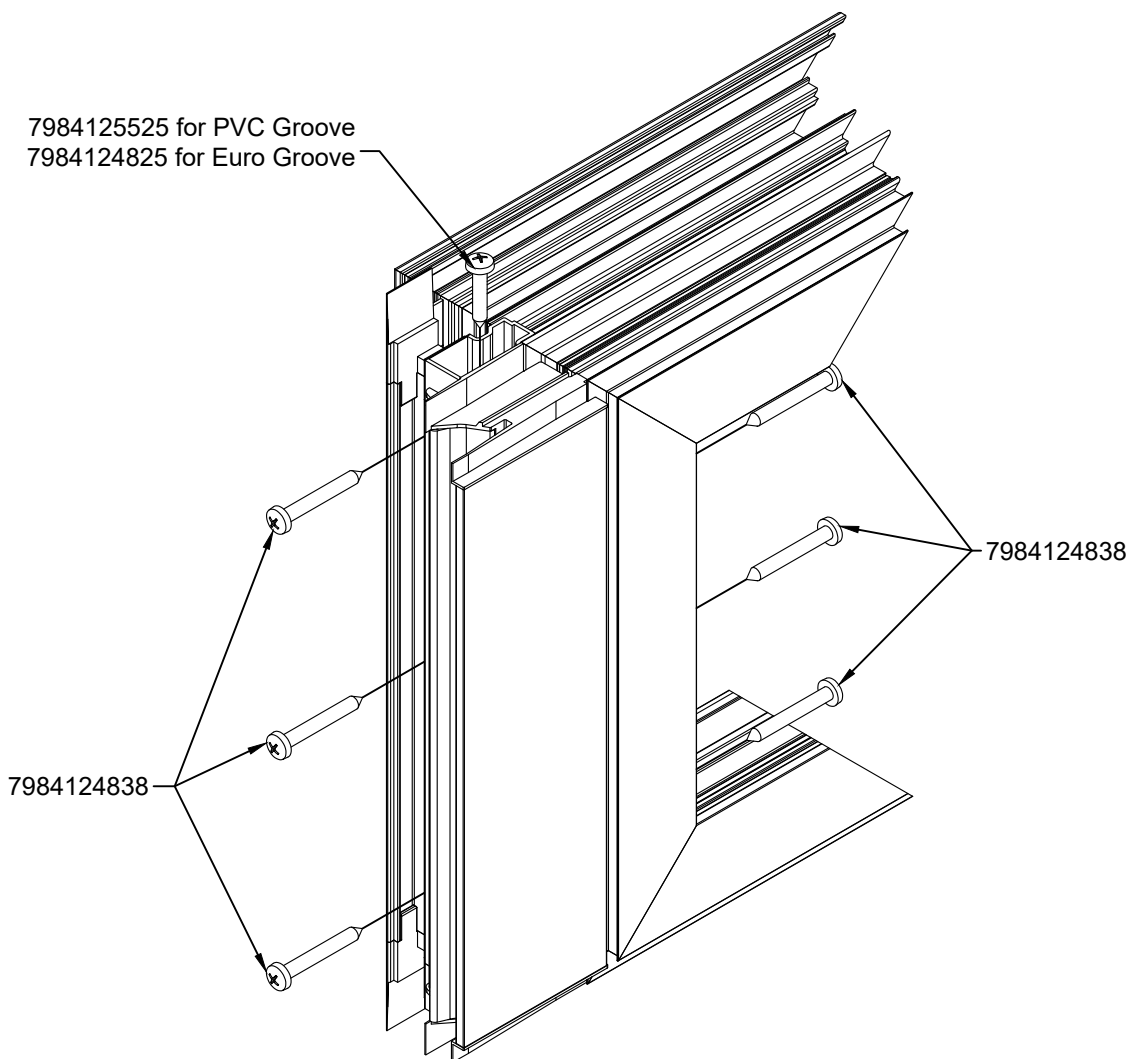

Screw at the profile's groove 50mm from the edge  
(upper and bottom).  
Step after that every 400mm.  
7984124838

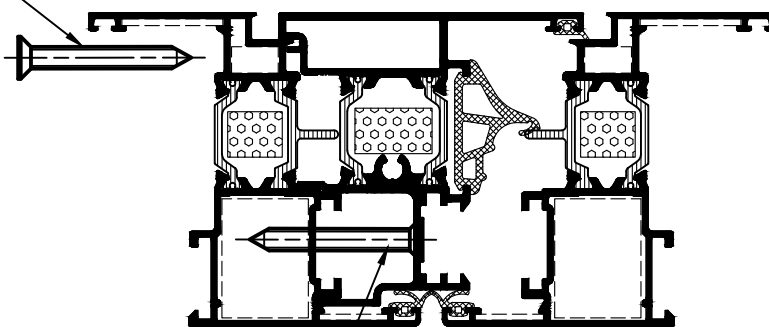

7984124838  
Screw 50mm from the edge (upper and bottom).  
Step after that every 400mm.



3006187903  
 End cap for adjoining profile S61879  
 Τάπα μπιβί S61879

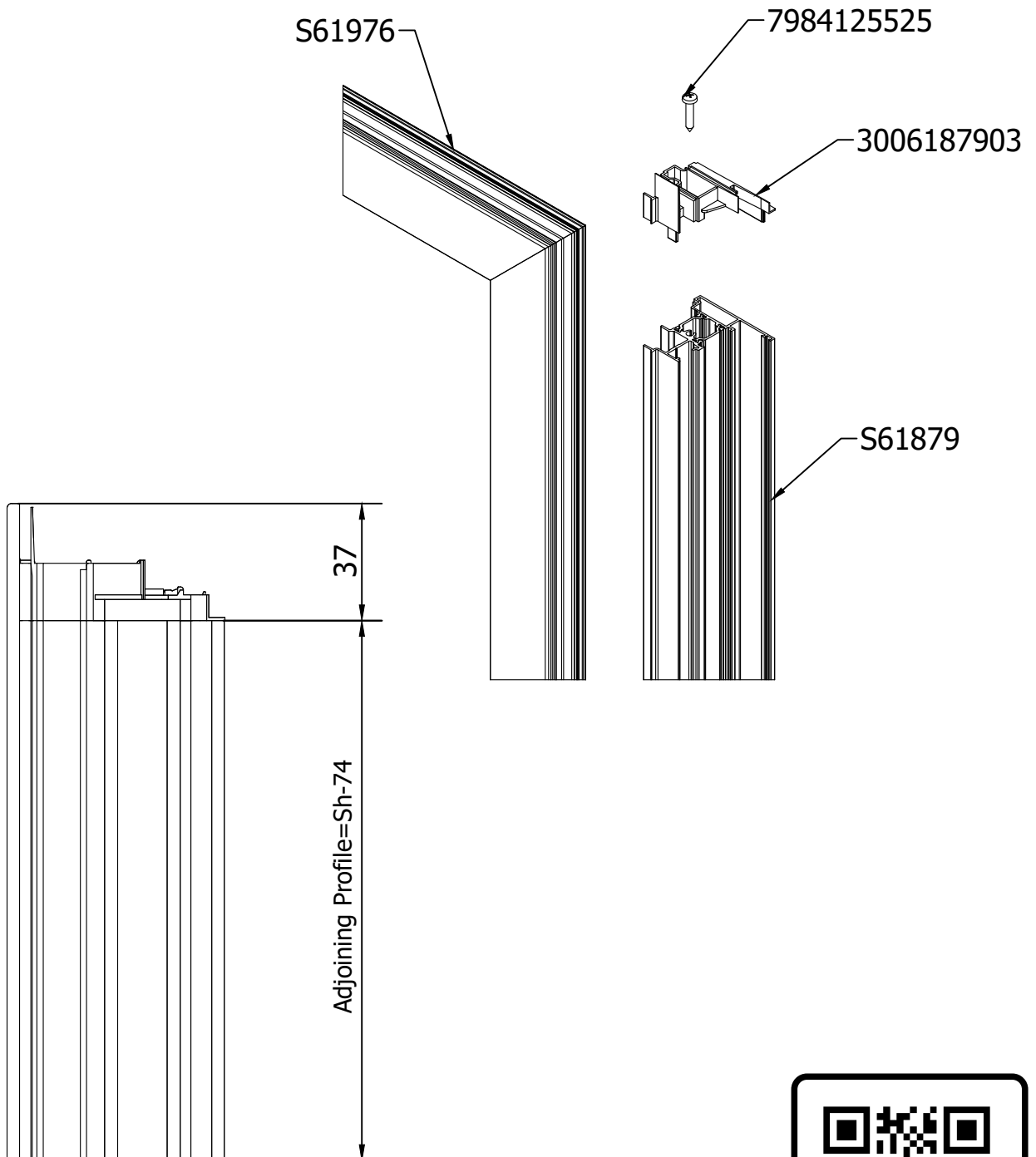

3006165803  
 End cap for adjoining profile S61658  
 Τάπα μπιβί S61658

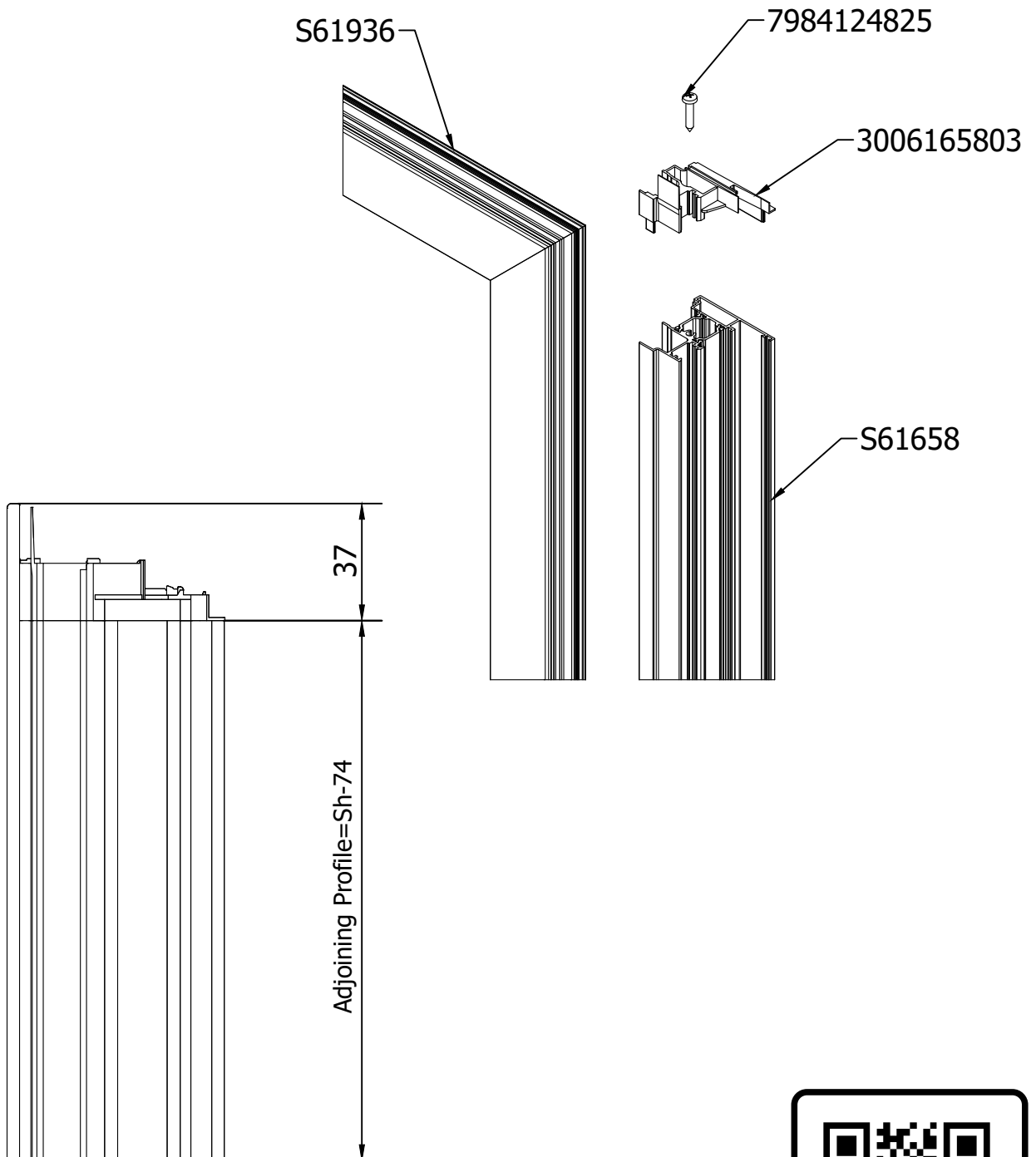

3006165903  
 Additional cap for low threshold  
 Πρόσθετη τάπα μπινιού για χαμηλό κατωκάσι

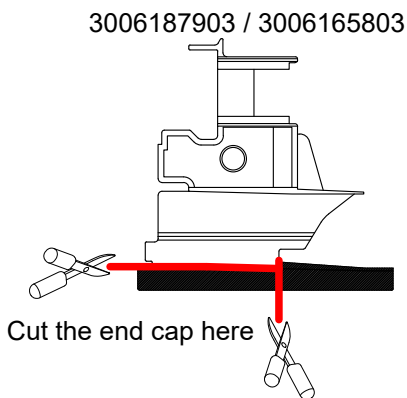

Εφαρμογή σιλικόνης πριν τη συναρμολόγηση  
 Apply silicone before assembling

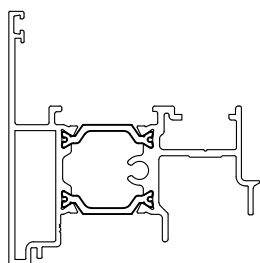

S61879  
 or  
 S61658

3006187903  
 or  
 3006165803

3006165903

7984124213

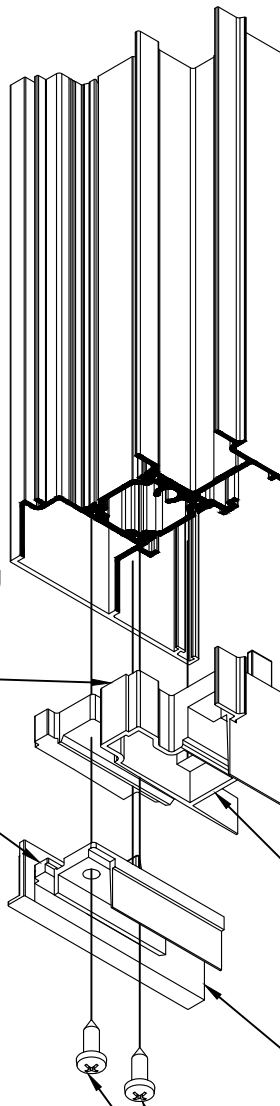
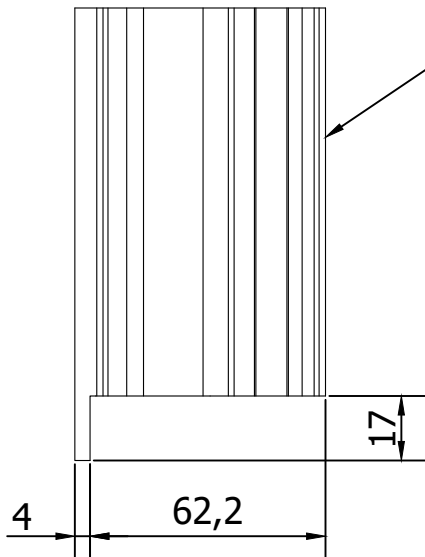

3106107203  
 End cap waterproofing for low threshold  
 Τάπα νεροσταλάκτη για χαμηλό κατωκάσι

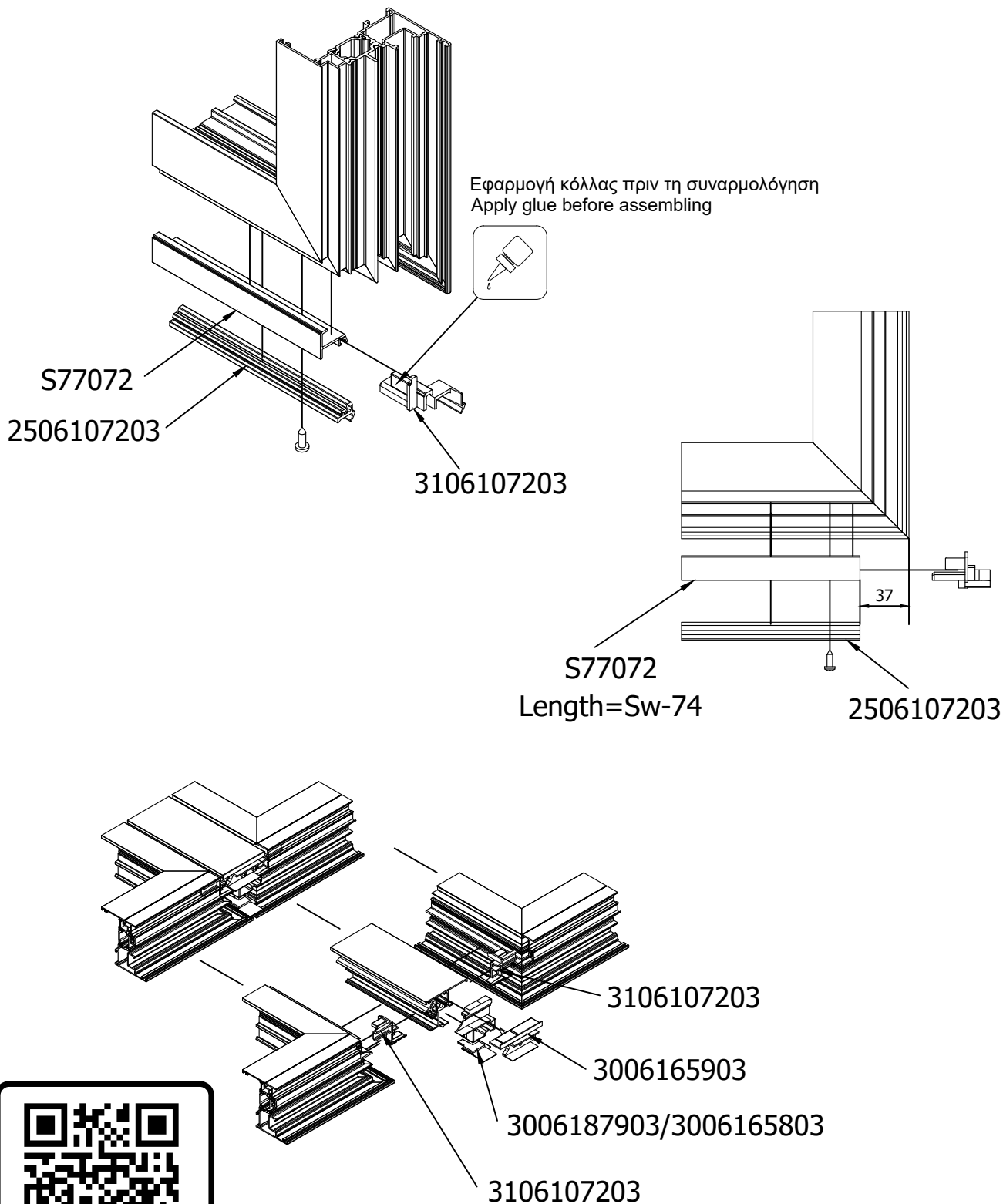

### 3106168403 End cap for low threshold Τάπα χαμηλού κατωκασίου

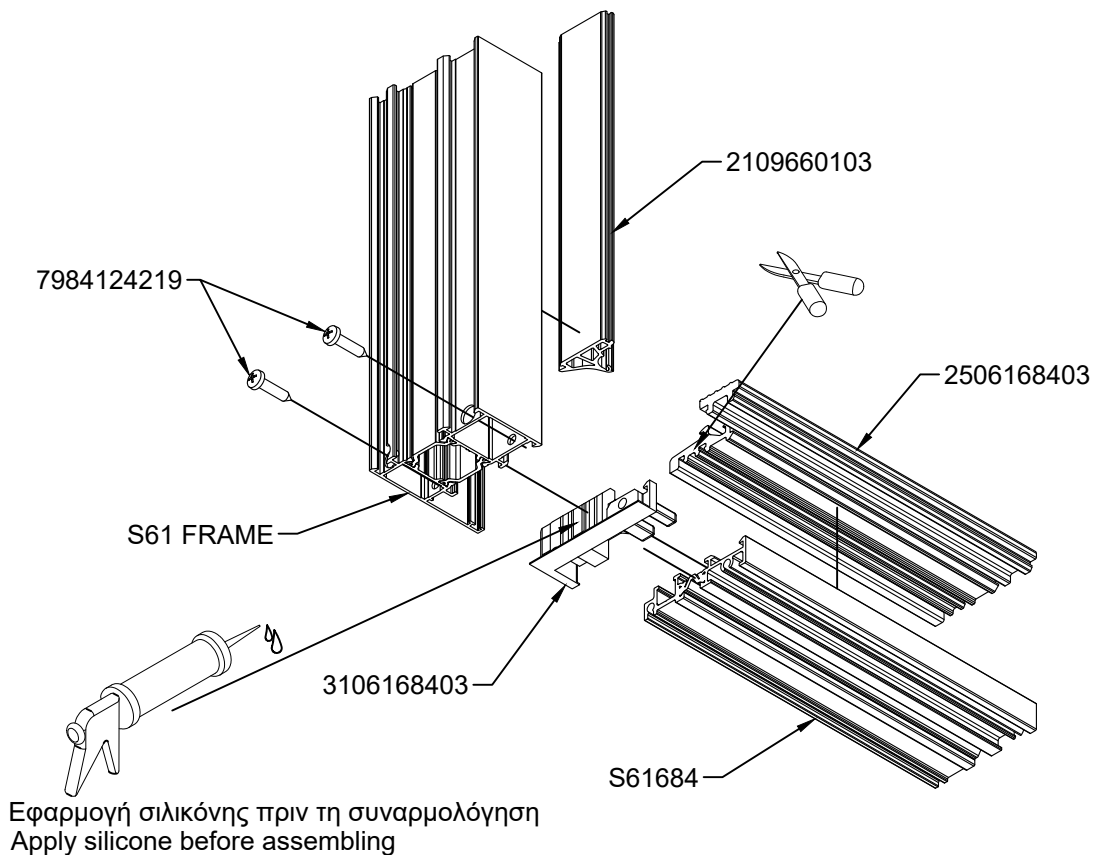

2506168403

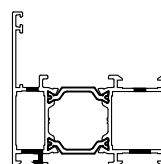

S61 FRAME

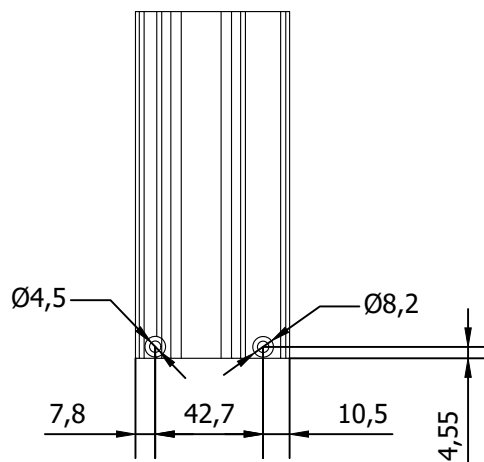
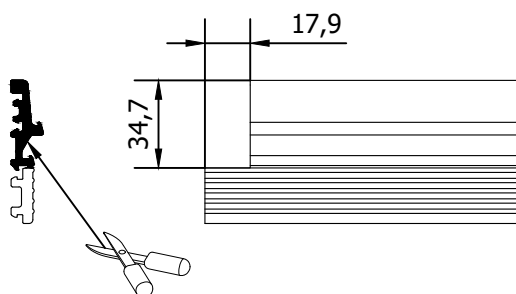

Alumil PVC Groove Mechanism - Single Sash - Low Threshold - Locking Plate Installation  
 Alumil PVC Groove Μηχανισμός - Μονόφυλλο - Χαμηλό Κατωκάσι - Εγκατάσταση Πλακάκι Κλειδώματος

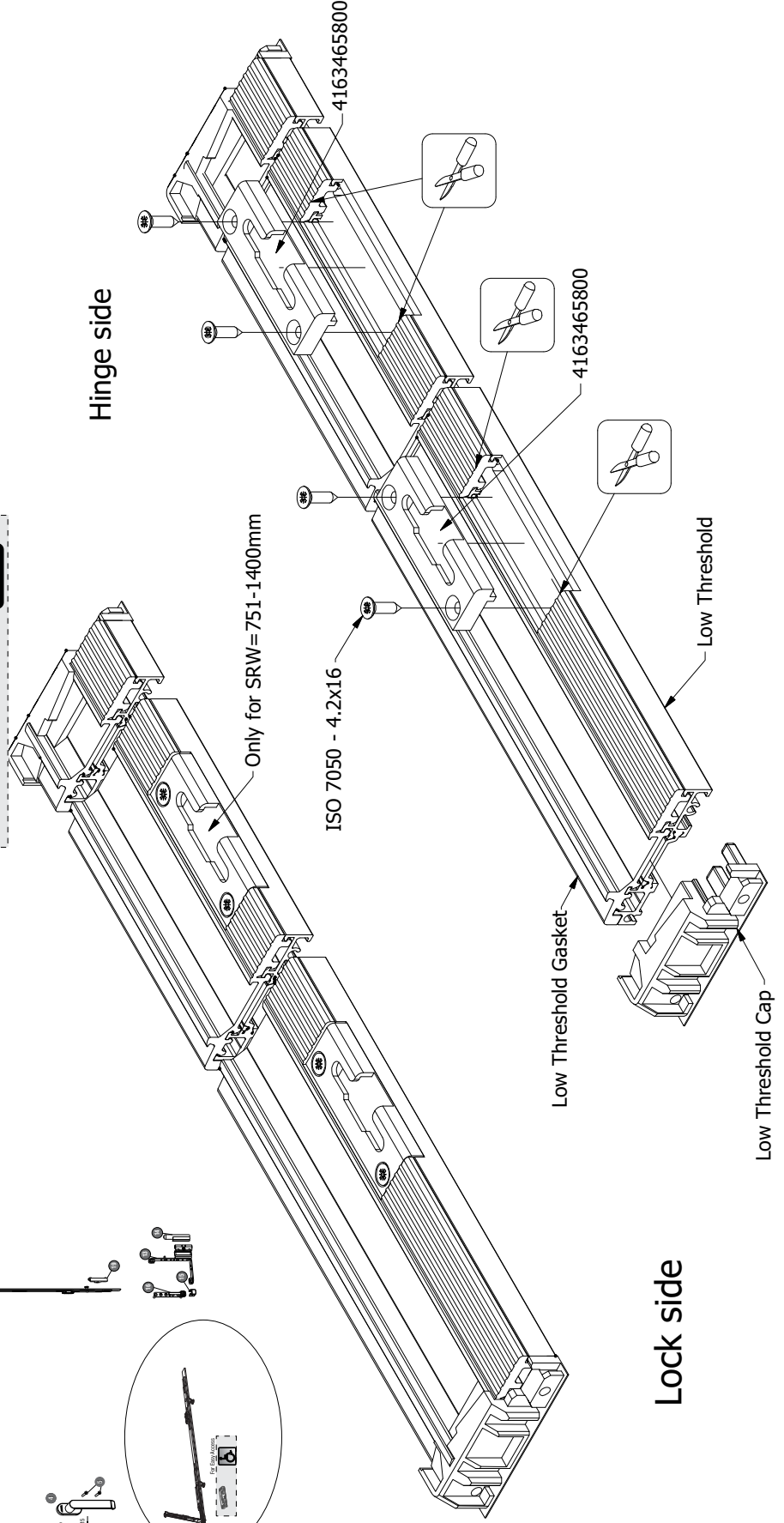
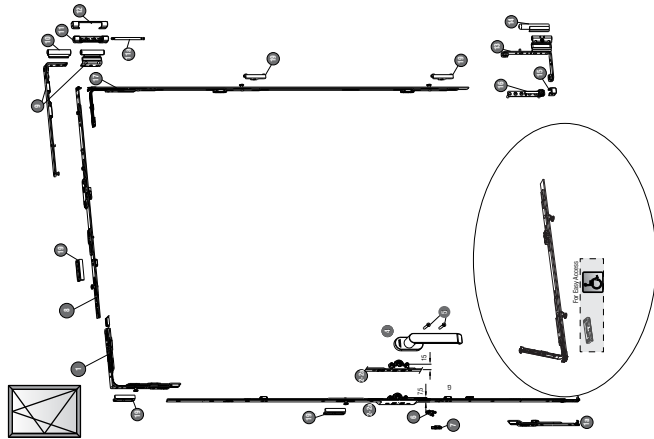
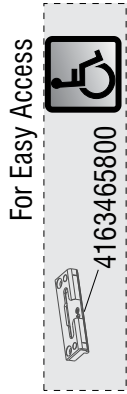
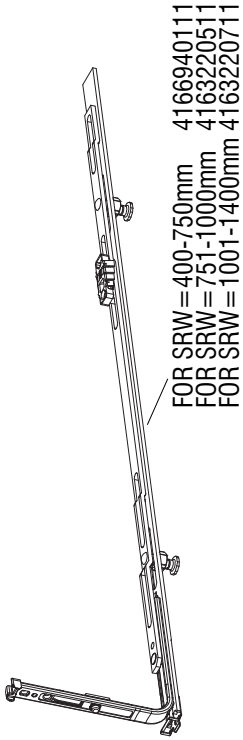
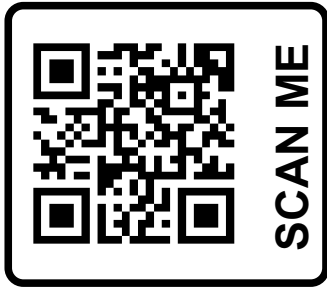

Alumil PVC Groove Mechanism - Single Sash - Low Threshold - Locking Plate Installation  
 Alumil PVC Groove Μηχανισμός - Μονόφυλλο - Χαμηλό Κατωκάσι - Εγκατάσταση Πλακάκι Κλειδώματος

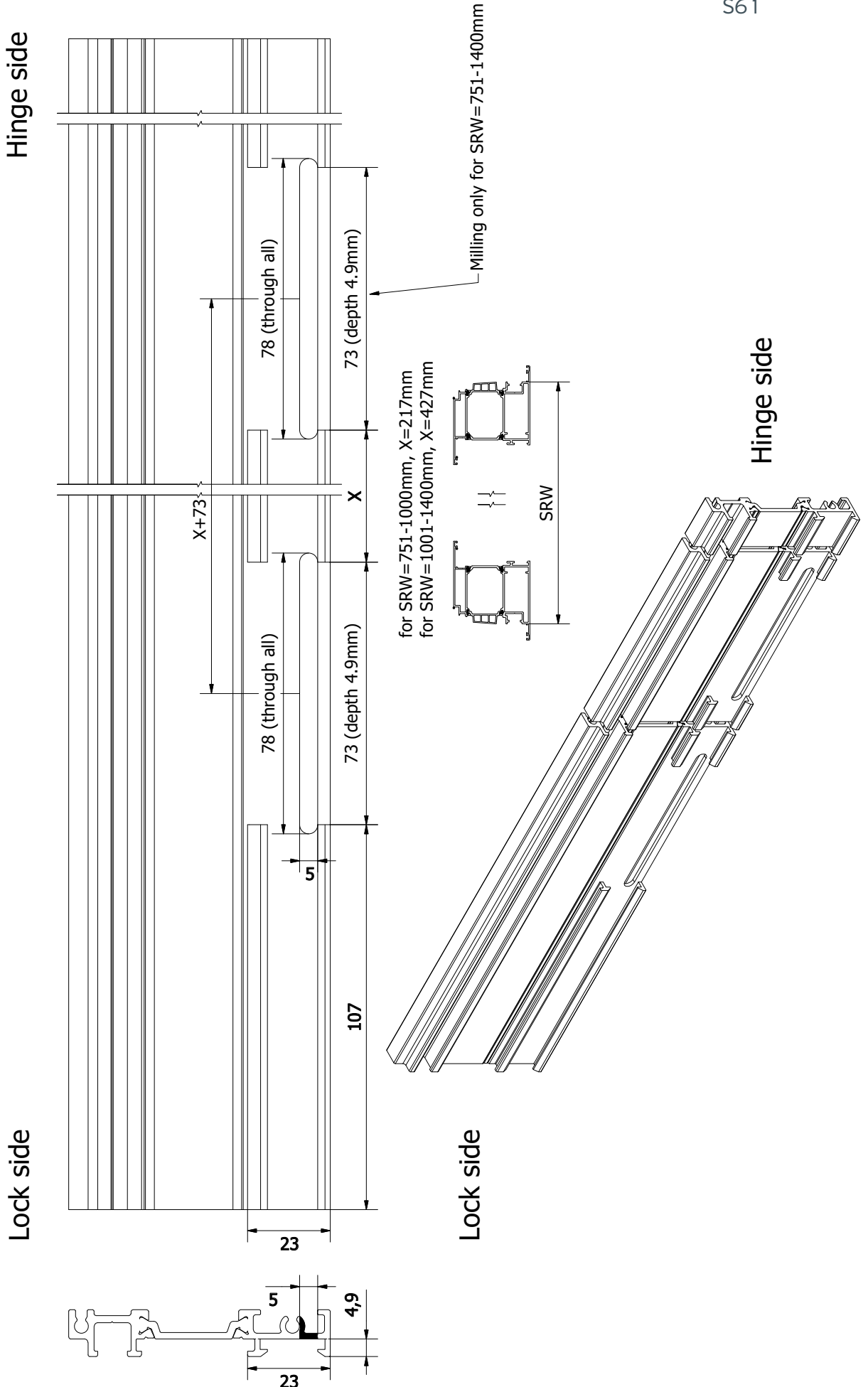



Alumil PVC Groove Mechanism - Double Sash - Low Threshold - Locking Plate Installation  
 Alumil PVC Groove Μηχανισμός - Δίφυλλο - Χαμηλό Κατωκάσι - Εγκατάσταση Πλακάκι Κλειδώματος

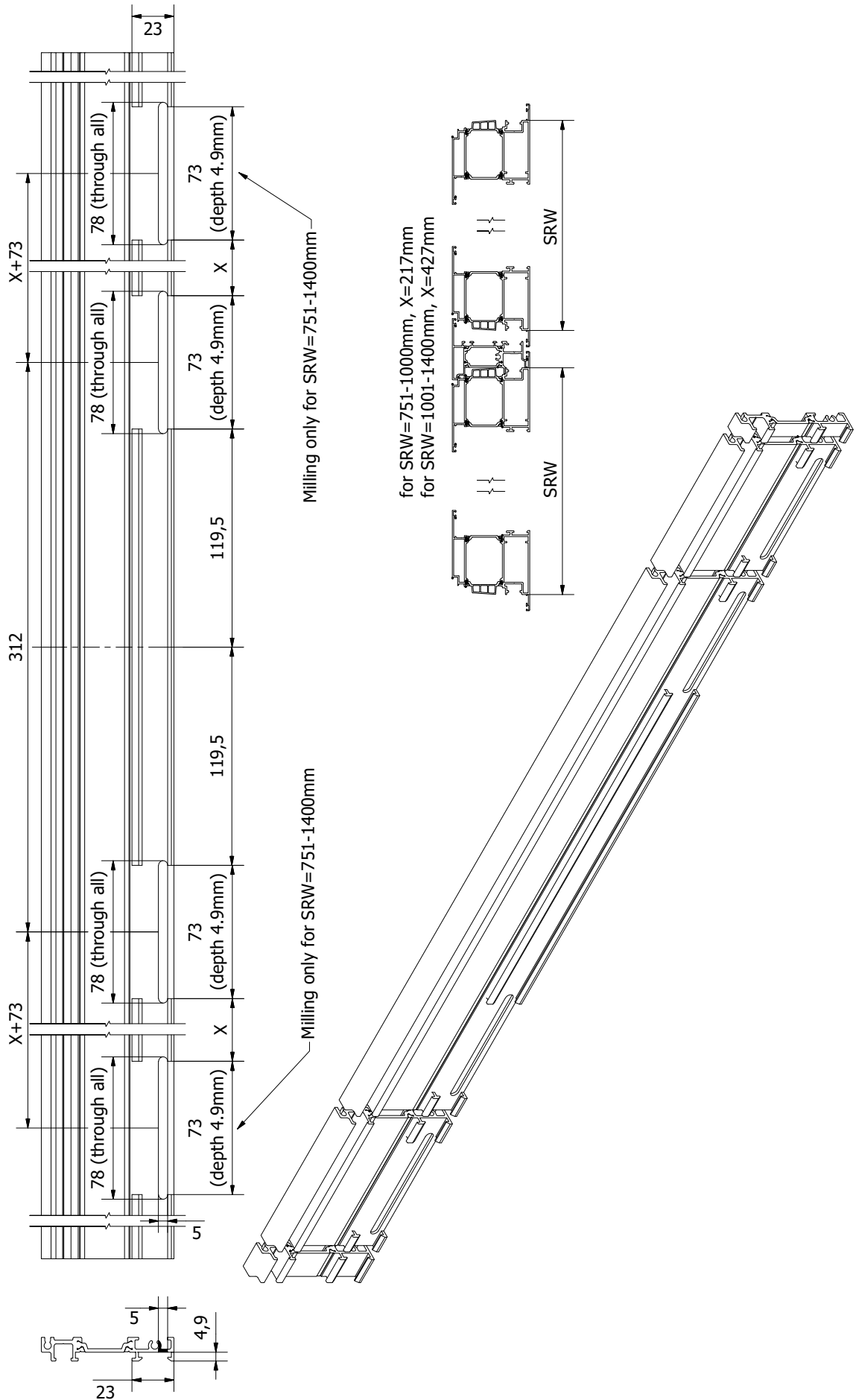

Alumil Euro Groove Mechanism - Single Sash - Low Threshold - Locking Plate Installation  
 Alumil Euro Groove Μηχανισμός - Μονόφυλλο - Χαμηλό Κατωκάσι - Εγκατάσταση Πλακάκι Κλειδώματος

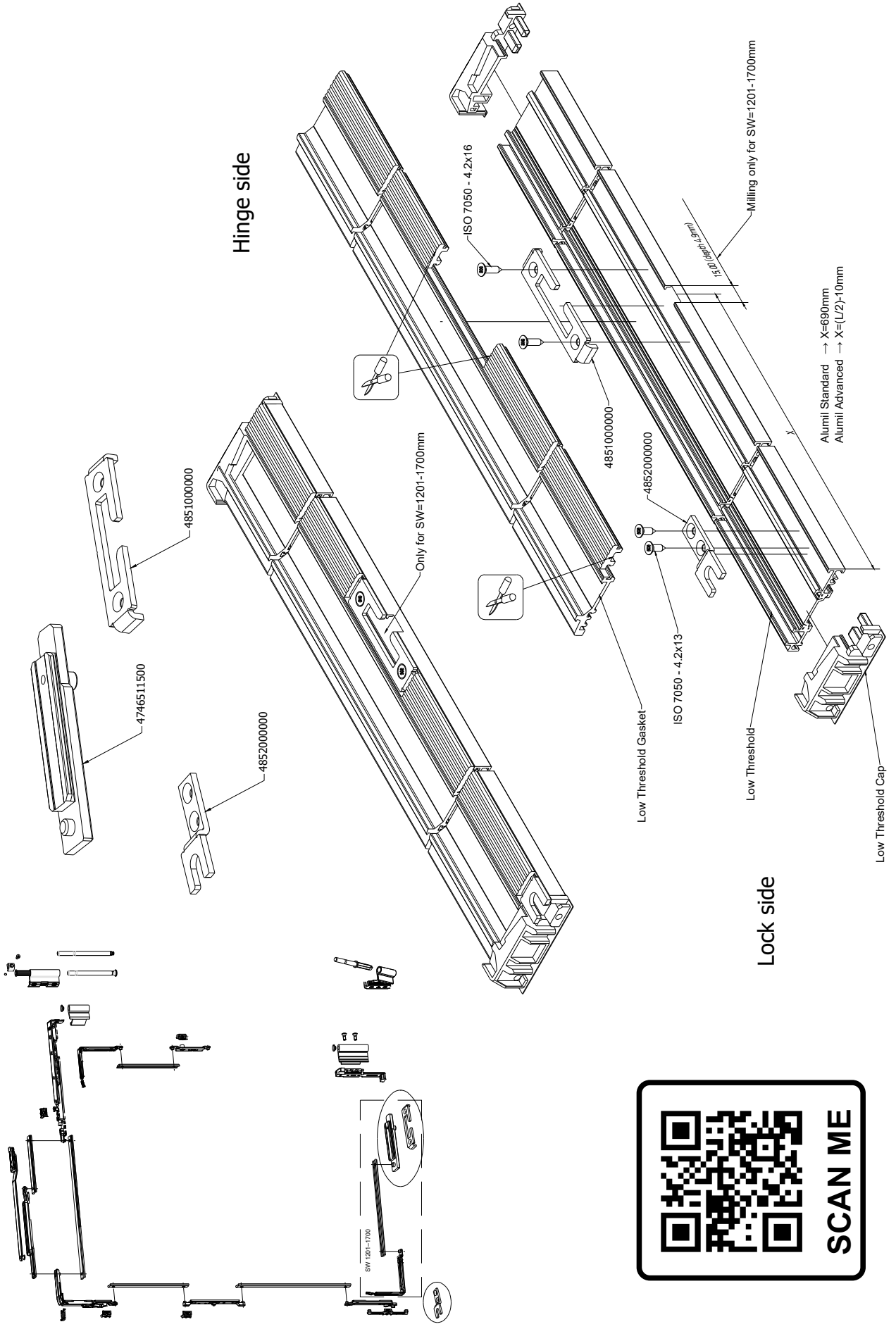

Alumil Euro Groove Mechanism - Double Sash - Low Threshold - Locking Plate Installation  
 Alumil Euro Groove Μηχανισμός - Δίφυλλο - Χαμηλό Κατωκάσι - Εγκατάσταση Πλακίκι Κλειδώματος

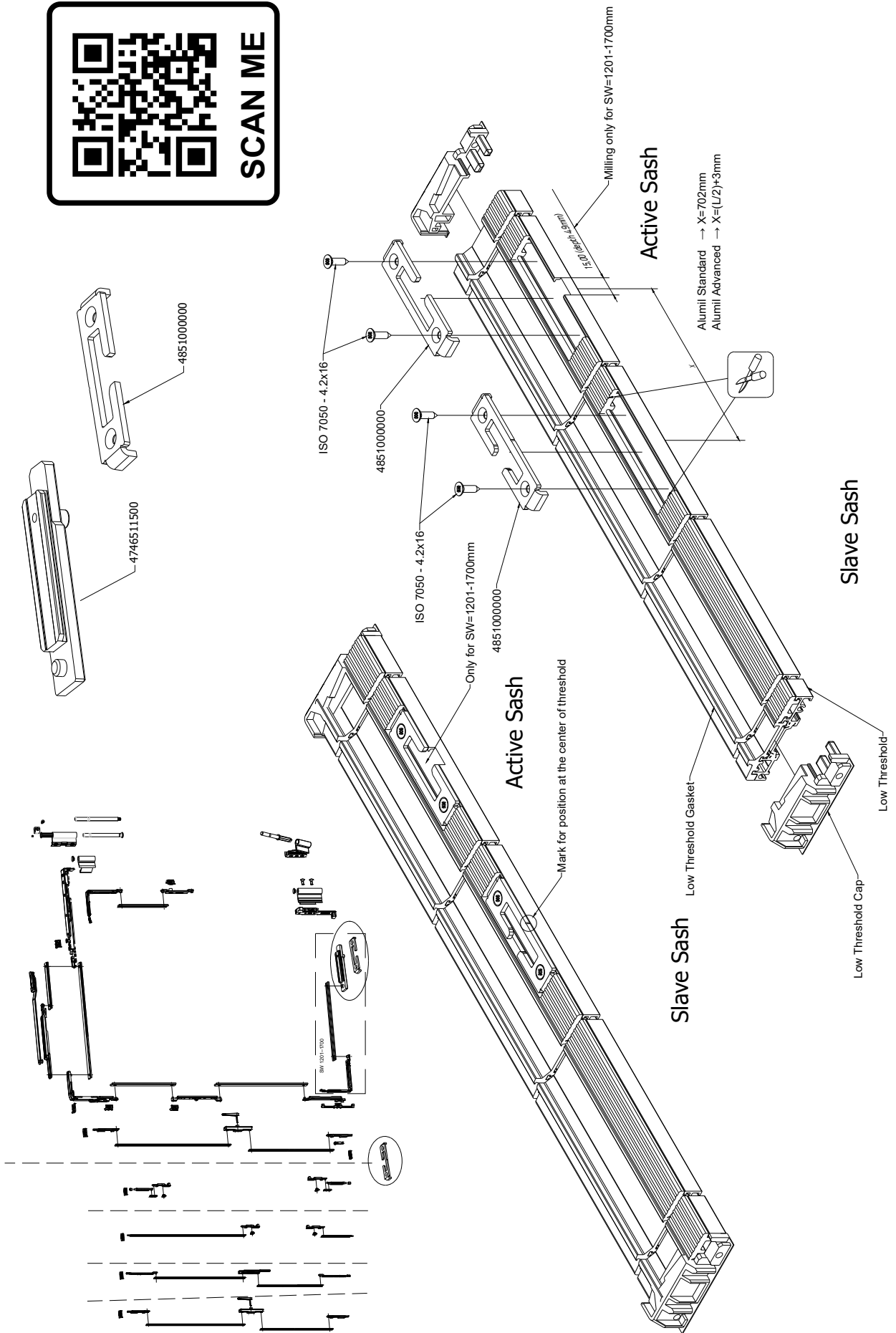

3106127003  
 End cap S61270 for door without threshold  
 Τάπα πρόσθετου S61270 για πόρτα χωρίς κατωκάσι

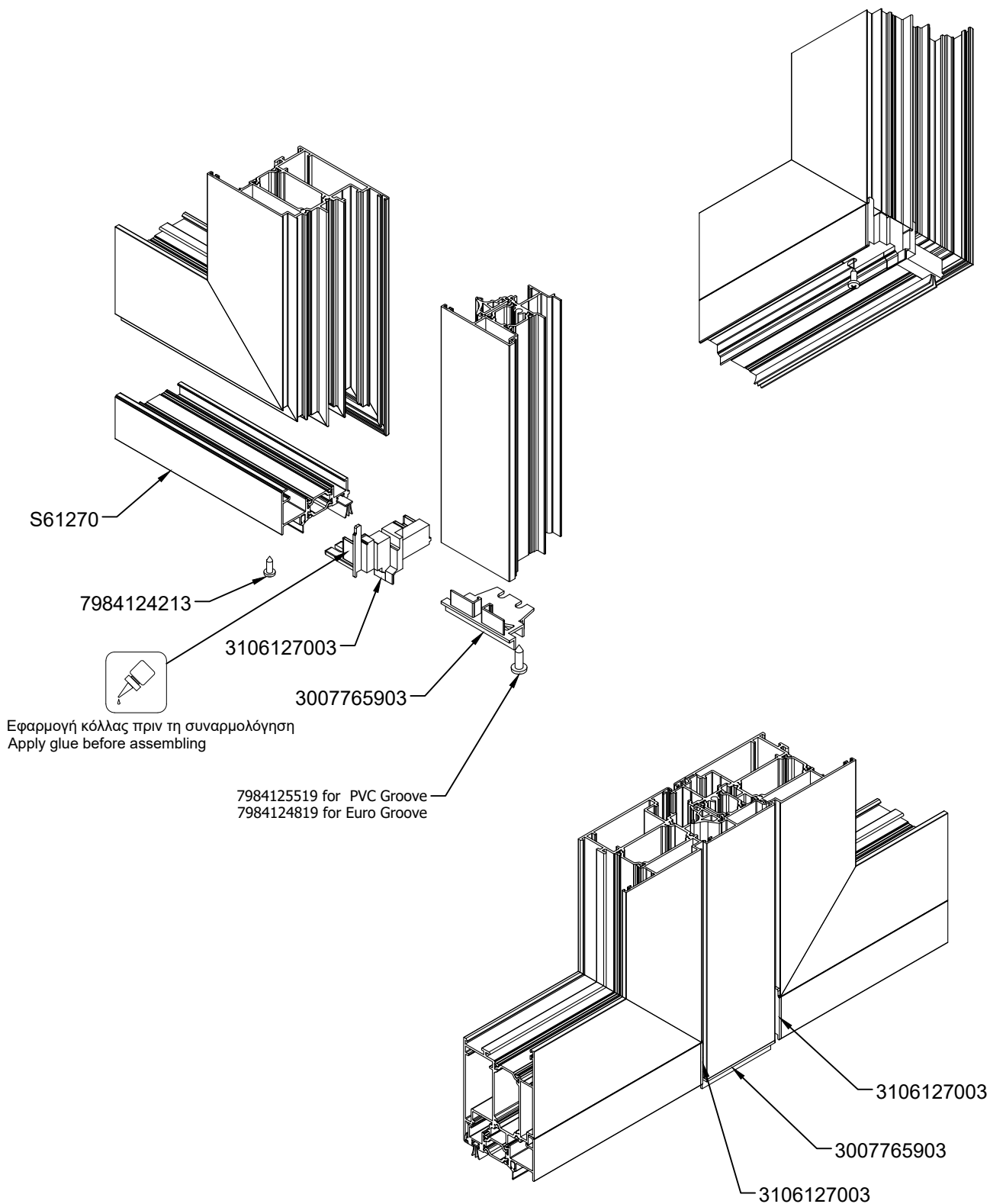

3107707903  
 End cap S77079 for door without threshold  
 Τάπα πρόσθετου S77079 για πόρτα χωρίς κατωκάσι

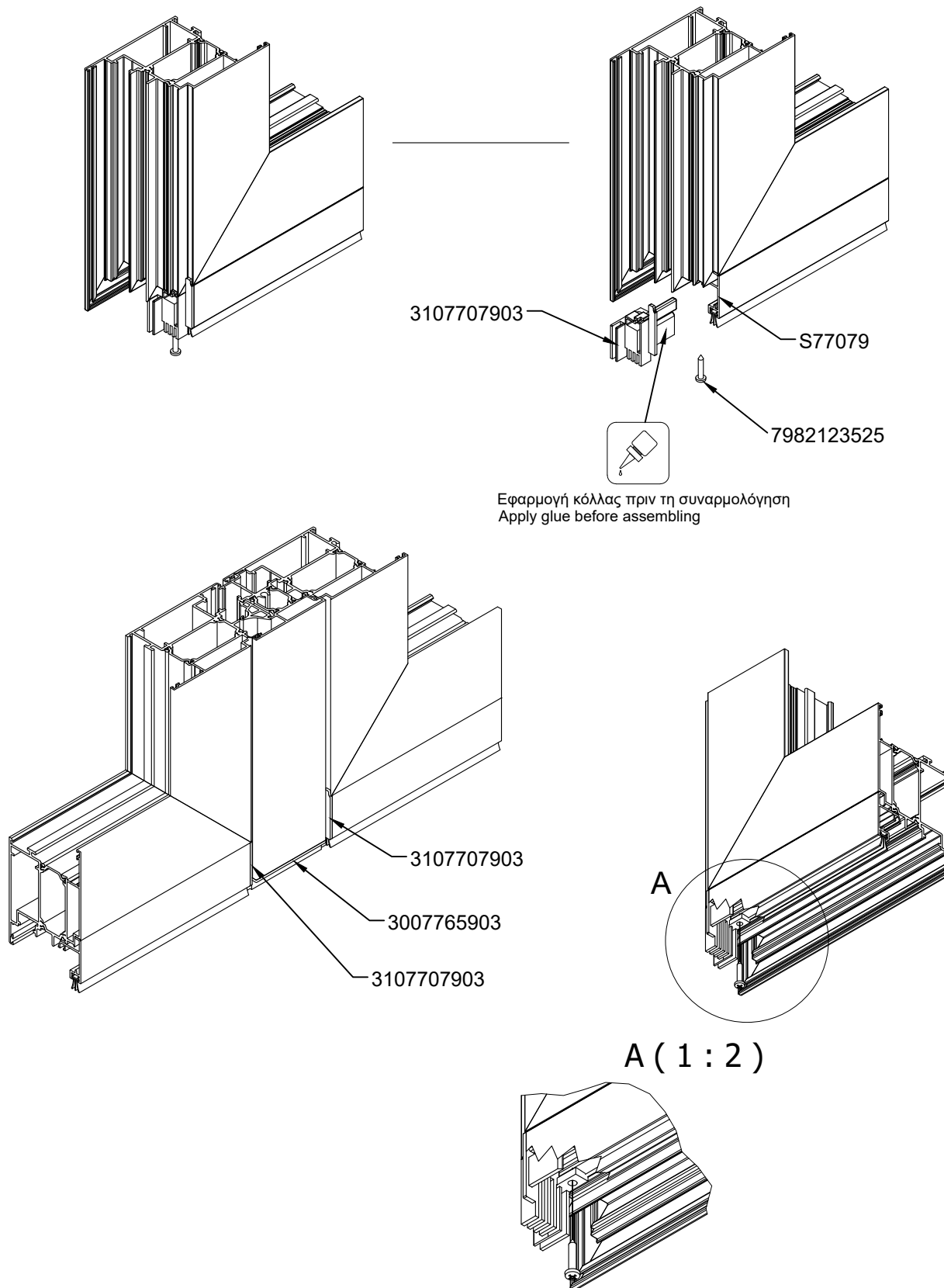

3007765903  
 End cap for double sash door without threshold  
 Τάπα μπινιού για δίφυλλη πόρτα χωρίς κατωκάσι

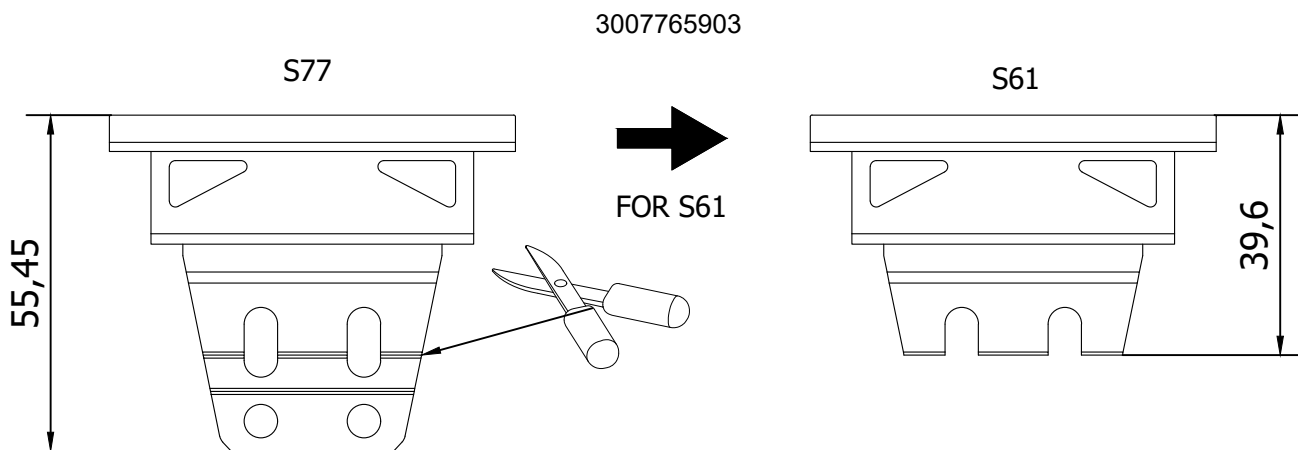
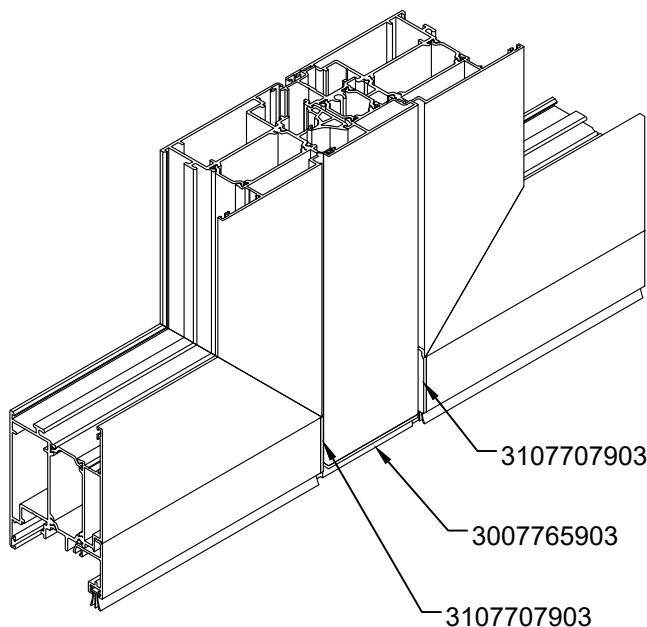
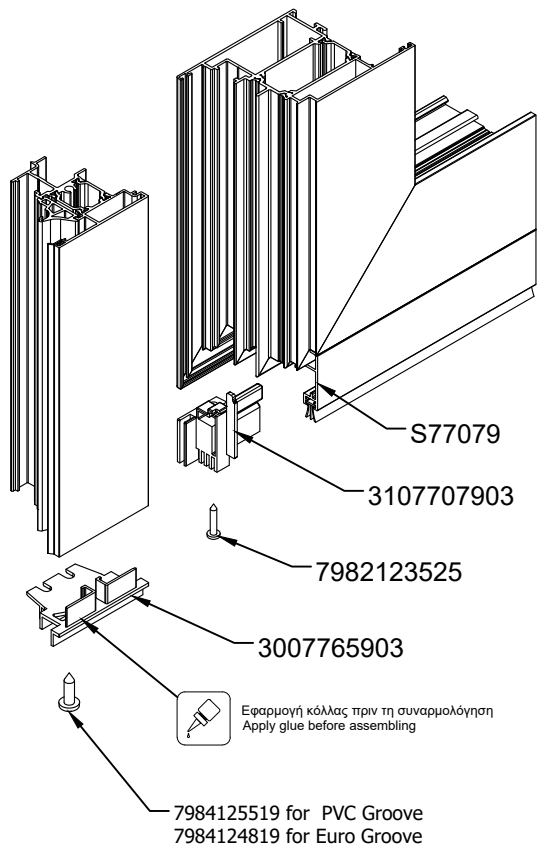

3107710003  
 End cap for door without threshold  
 Τάπα κάσας για πόρτα χωρίς κατωκάσι

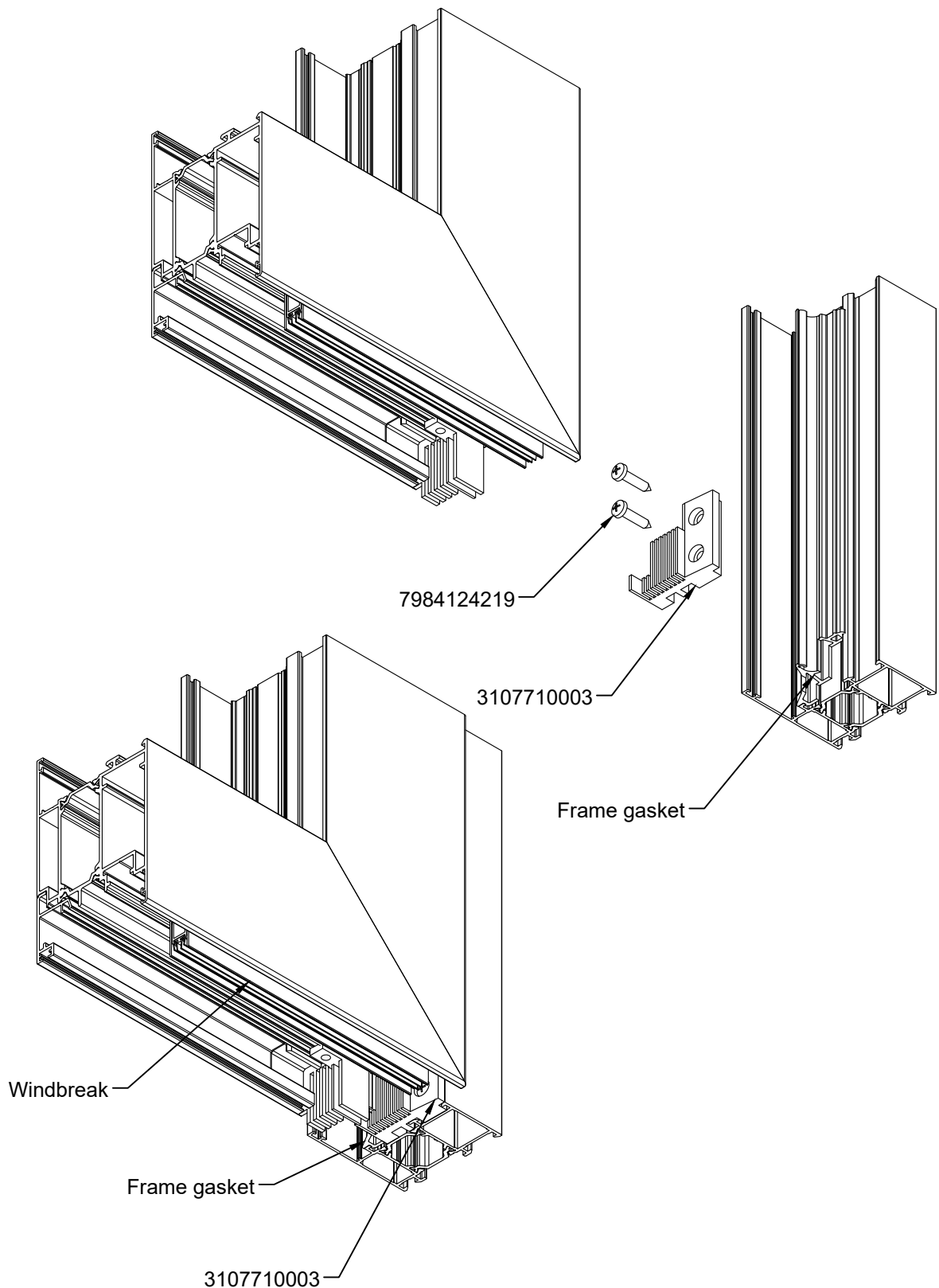



## T-profile connection with nails Συναρμολόγηση Ταυ με καρφί

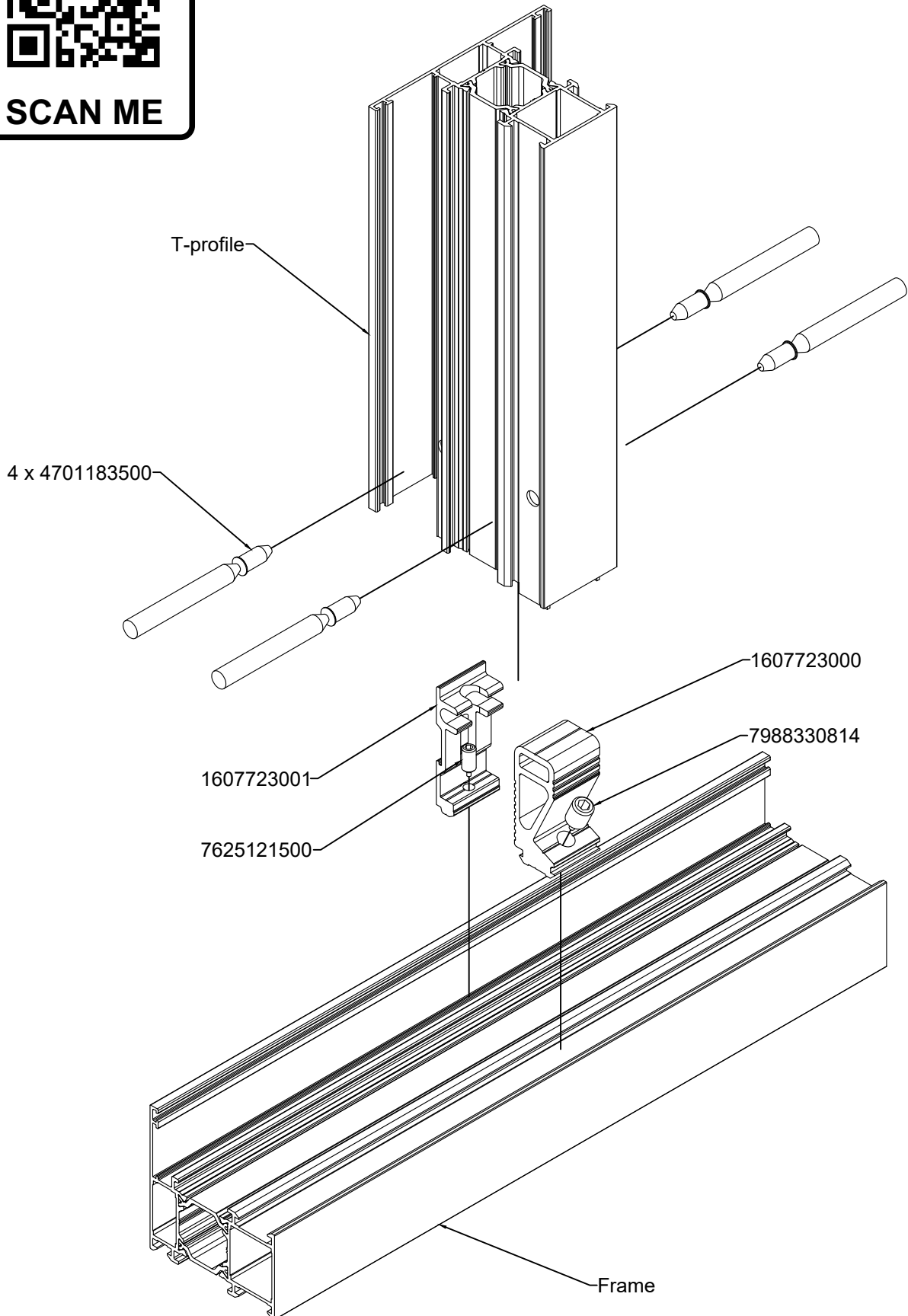

S67000 - 4706700100  
 Slide in trim profile  
 Κουμπωτό αρμοκάλυπτρο

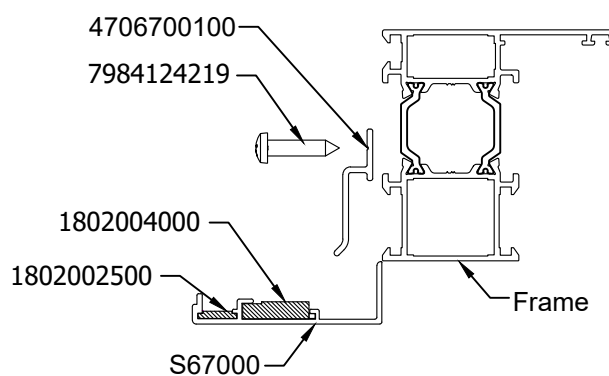
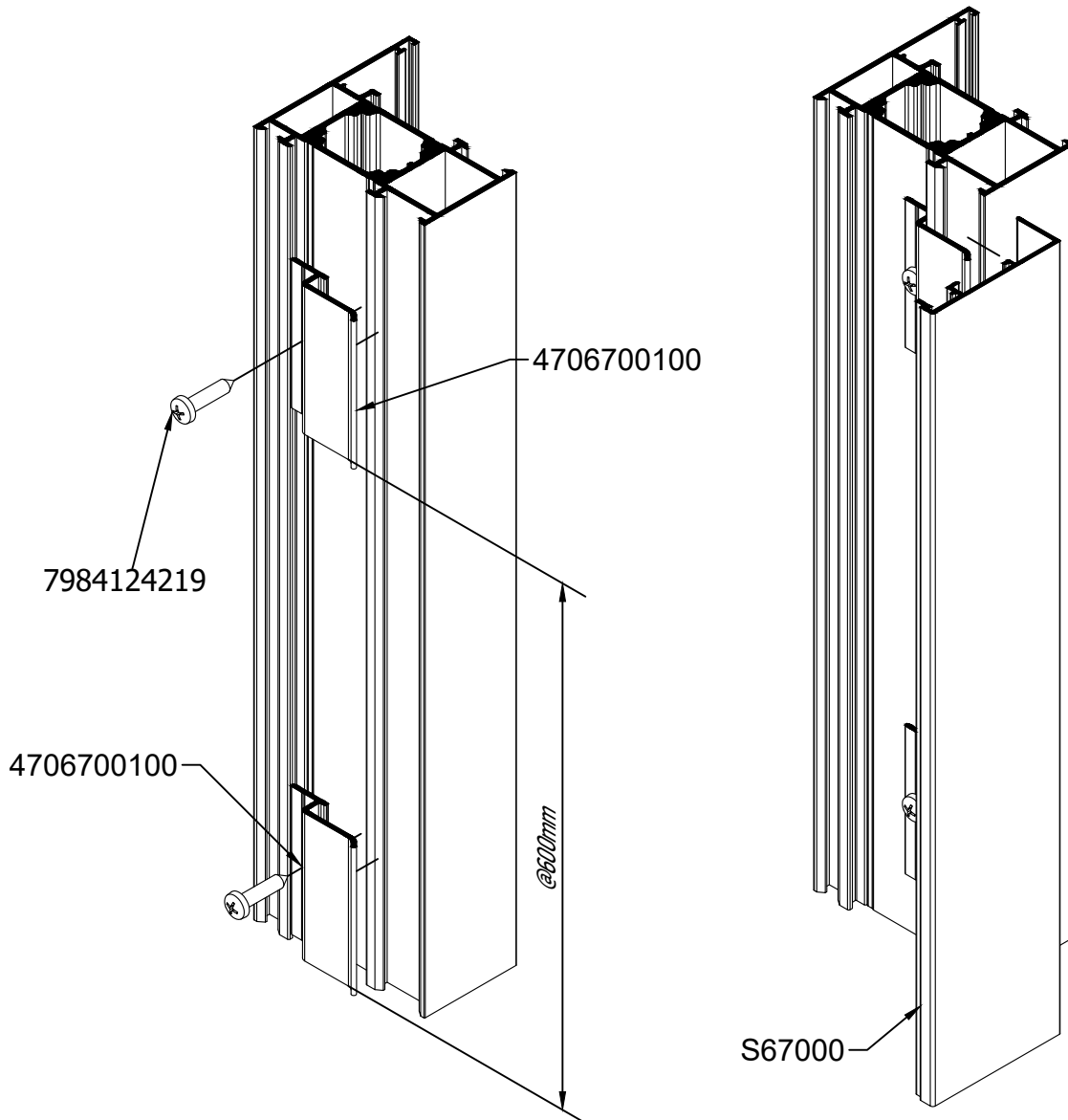

S67000 - 4706700100  
 Slide in trim profile  
 Κουμπωτό αρμοκάλυπτρο

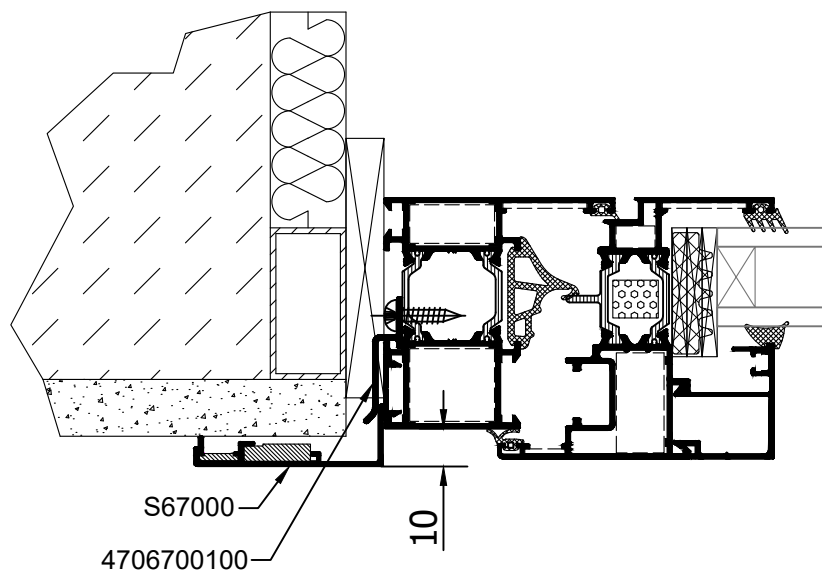
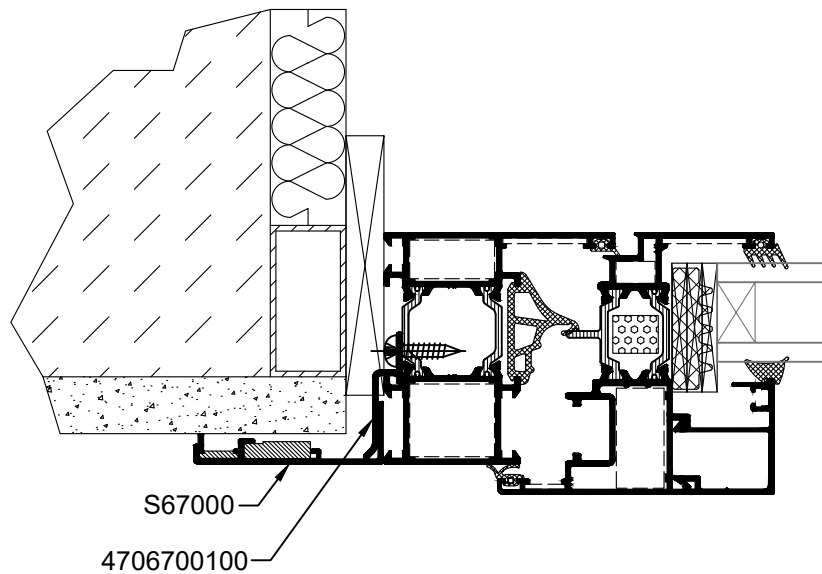

S67000 - 4706700200  
 Slide in trim profile for rolling shutters  
 Κουμπωτό αρμοκάλυπτρο για ρολά

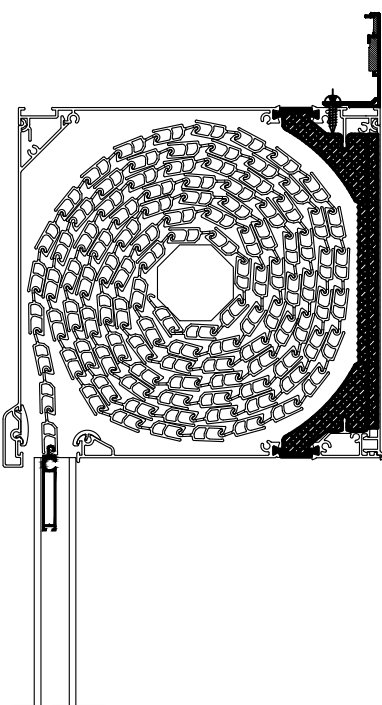
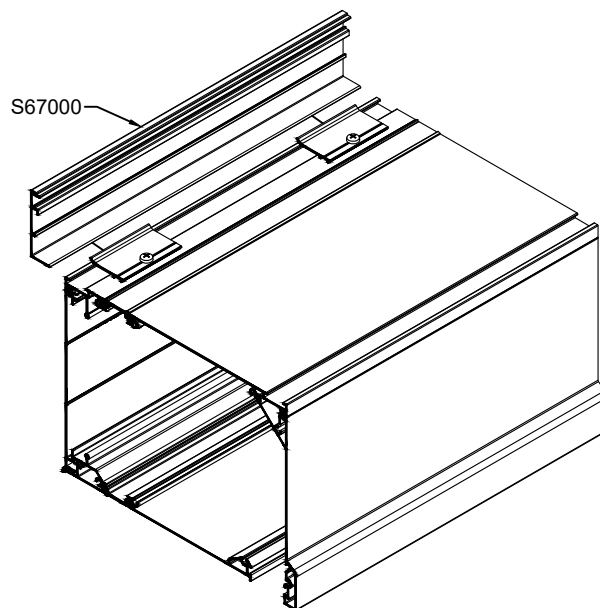
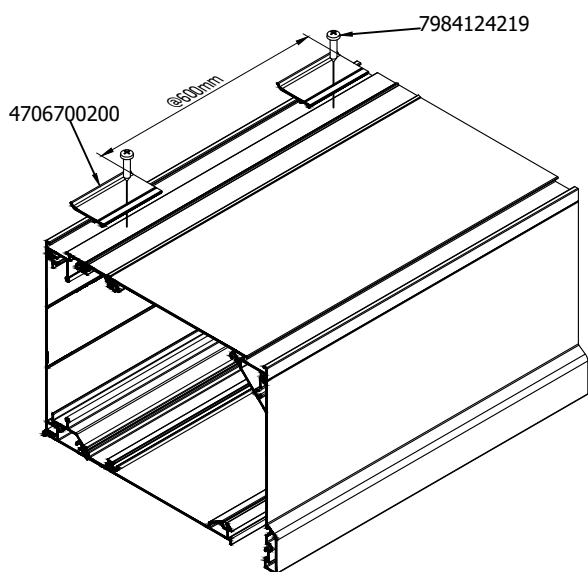

S67000  
Slide in trim profile  
Κουμπωτό αρμοκάλυπτρο

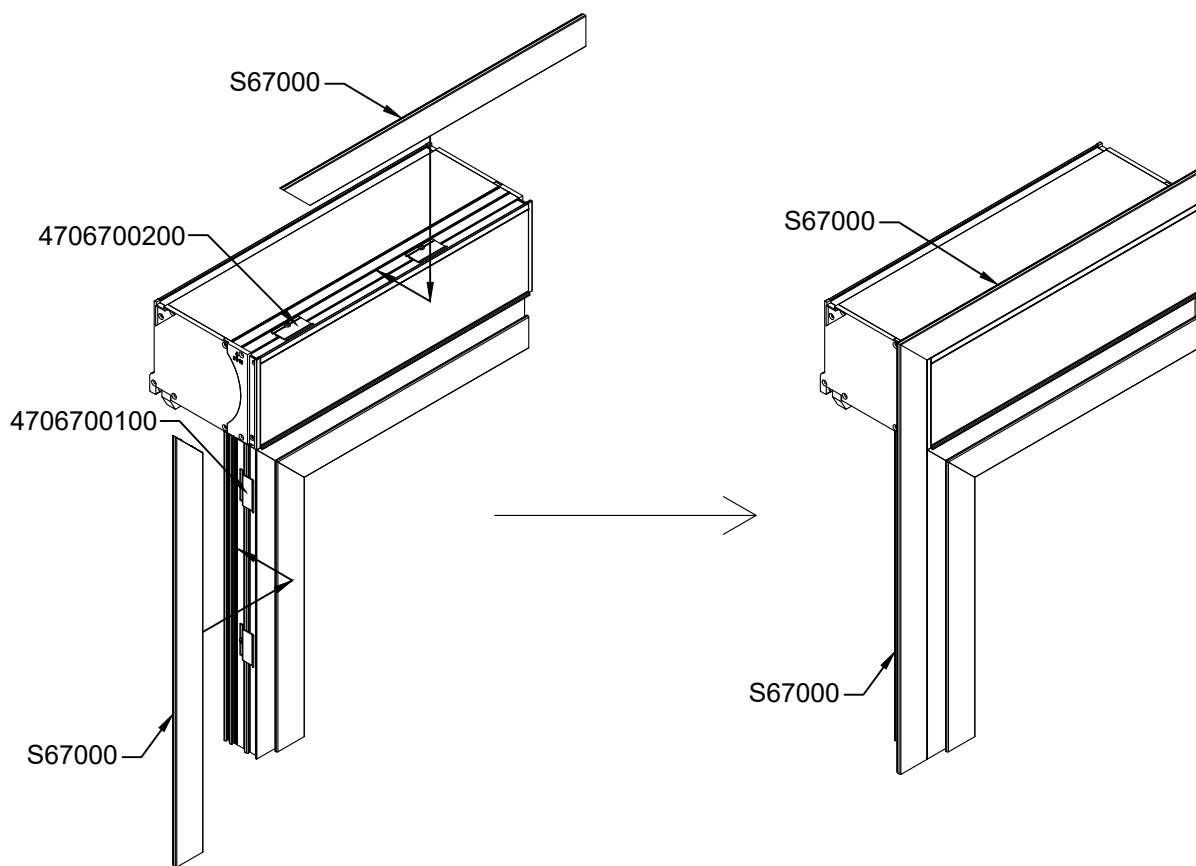

S67000  
 Slide in trim profile for window with rolling shutter  
 Κουμπωτό αρμοκάλυπτρο για παράθυρο με ρολό

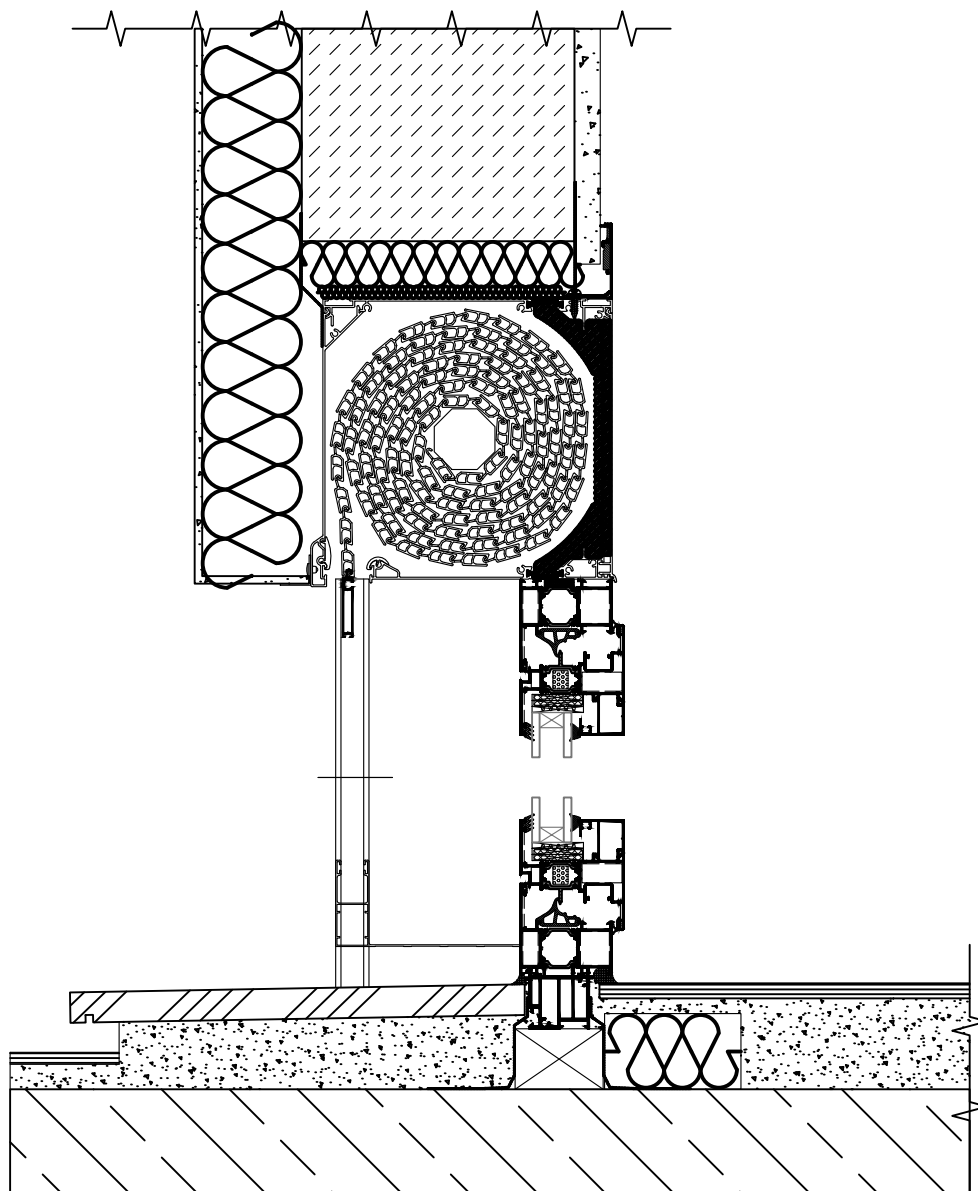

### S67000

Slide in trim profile for window with rolling shutter  
 Κουμπωτό αρμοκάλυπτρο για παράθυρο με ρολό

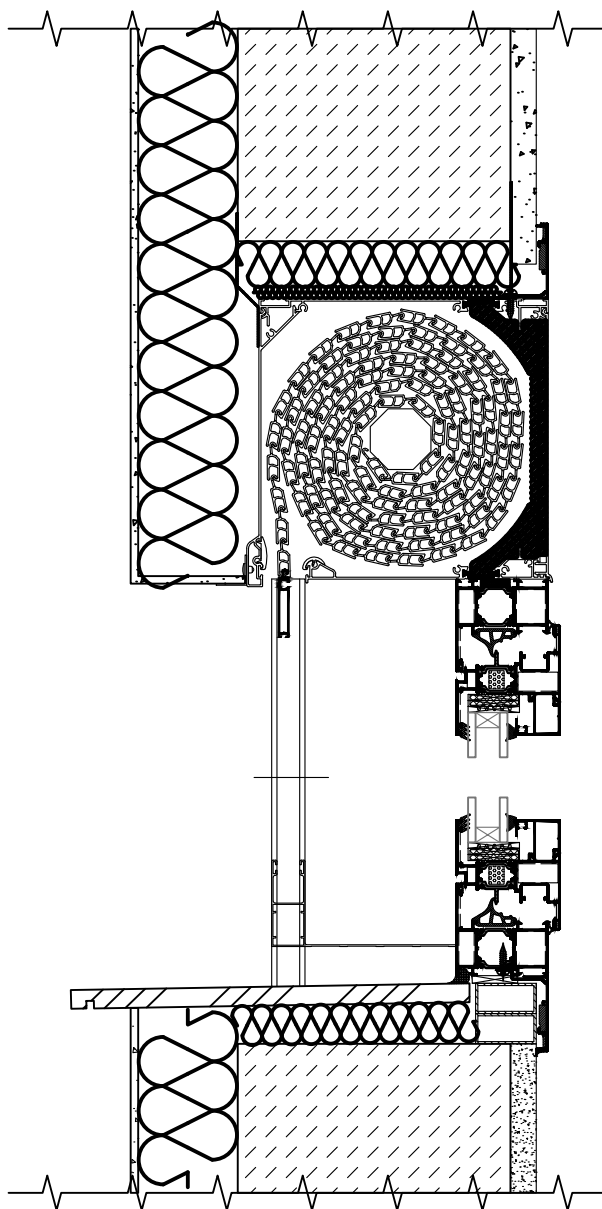

### S67000

Slide in trim profile for window with rolling shutter  
Κουμπωτό αρμοκάλυπτρο για παράθυρο με ρολό

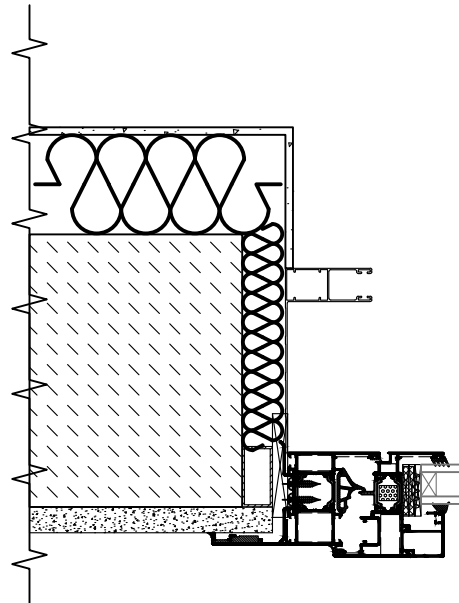

3107701003  
Drainage end cap spring S77010  
Εξάρτημα συγκράτησης νεροσταλάκτη S77010

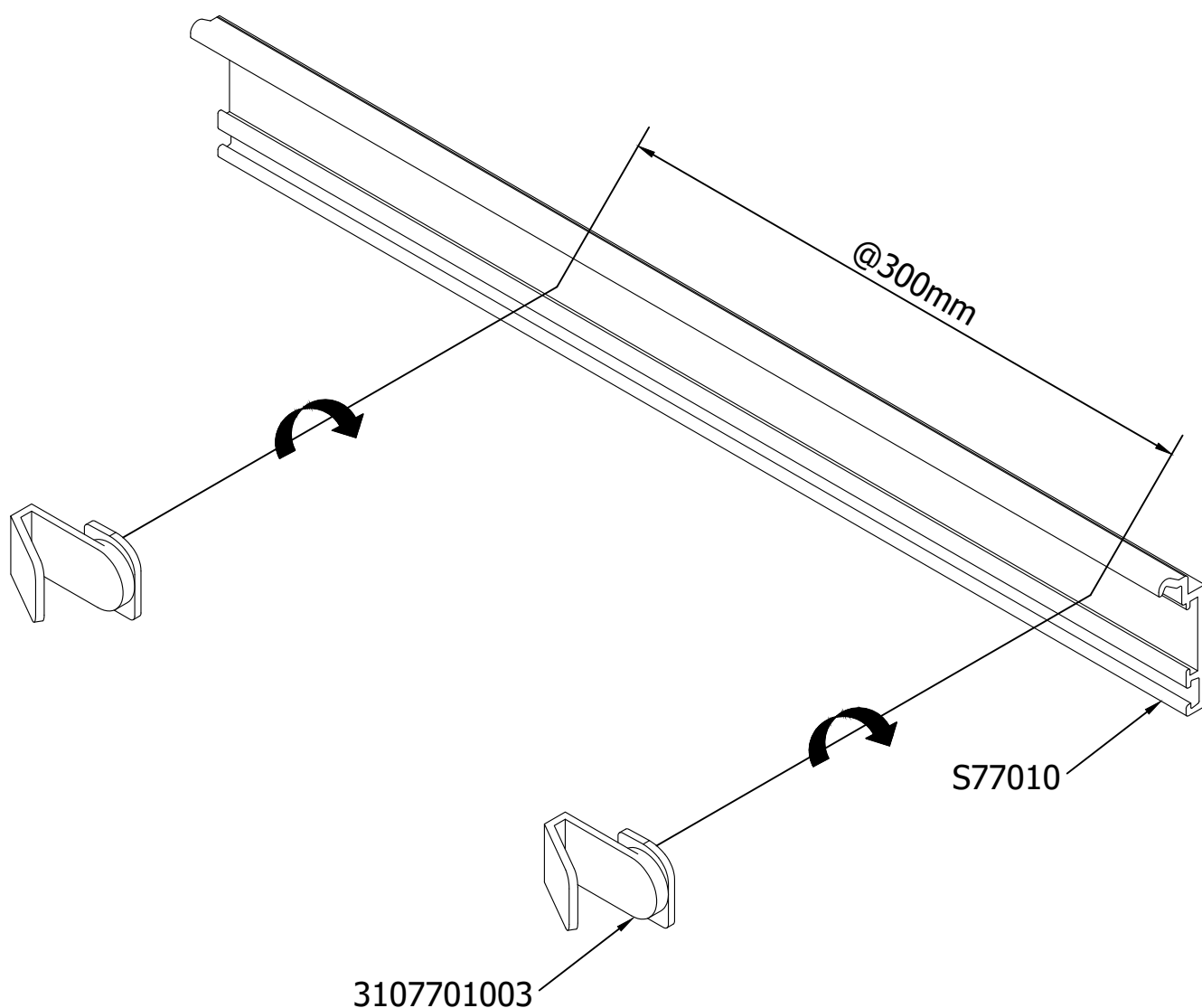

## 3107701003 Drainage end cap spring S77010 Εξάρτημα συγκράτησης νεροσταλάκτη S77010

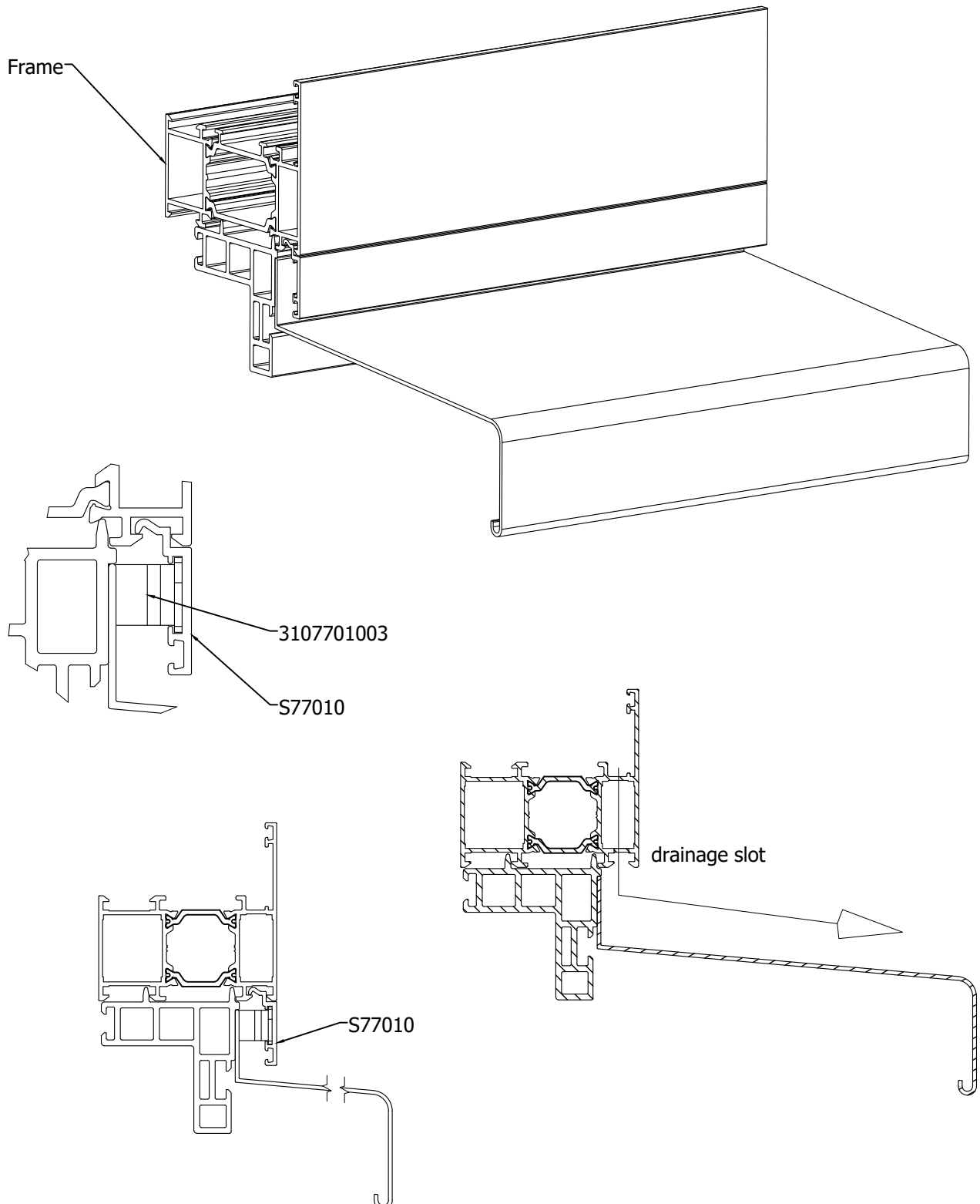

## Setting blocks installation Τακάρισμα υαλοπίνακα

	Τακάκια θέσης - Filling spaces
	Τακάκια βάρους υάλωσης - Glassload support and frame squariness

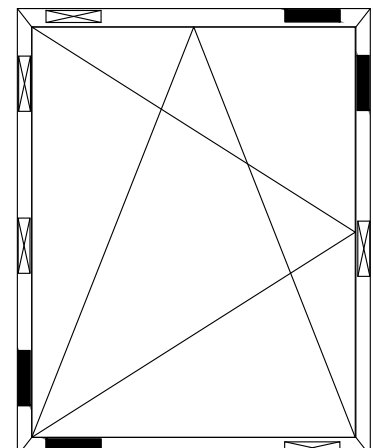
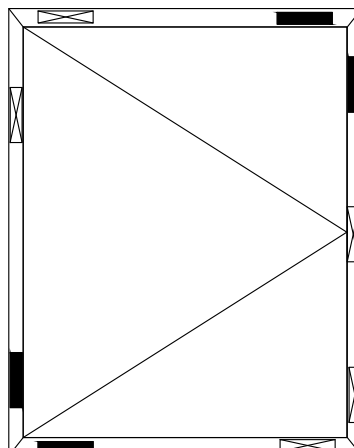
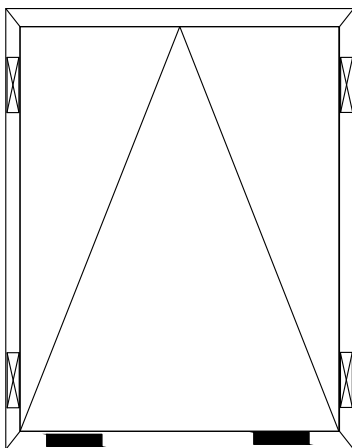
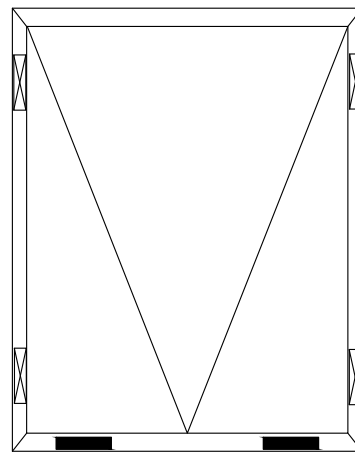
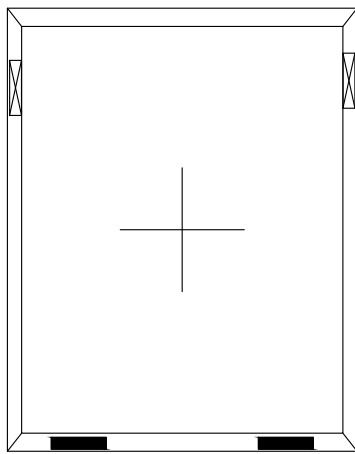

## Glazing gasket installation Τοποθέτηση ελαστικών υάλωσης

### Exterior glazing gasket installation Τοποθέτηση εξωτερικού ελαστικού υάλωσης

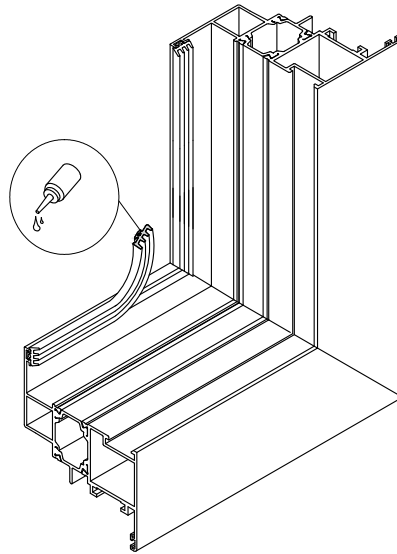

### Interior glazing gasket installation Τοποθέτηση εσωτερικού ελαστικού υάλωσης

